



## COURSE HANDOUT

# ELEMENTRY FIRST AID



## **NAVIGATOR MARITIME ACADEMY**

(Approved by DG Shipping, Ministry of Shipping, Govt. of India)

(MTI No. : 108025 & Approval No.: TR/A/58/2019)

Plot No – 342, Fathepur Sikri Road, Patholi, Agra, Uttar Pradesh

Tel No: +91-8006891234

E-mail: [training@navigatormaritime.ac.in](mailto:training@navigatormaritime.ac.in)

Web: [www.navigatormaritime.ac.in](http://www.navigatormaritime.ac.in)

# ELEMENTARY FIRST AID

## INDEX

<u>Chapter</u>	<u>Subject</u>	<u>Page No.</u>
01	General Principles of First Aid	3 – 4
02	Body Structure & Functions	5 – 12
03	Casualty	13 – 14
04	Positioning of Casualty	15 – 17
05	Unconscious Casualty	18 – 21
06	Resuscitation	22 – 29
07	Bleeding	30 – 36
08	Management of Shock	37 – 40
09	Burns, Scalds and Accidents caused by Electricity	41 – 44
10	Rescue and Transportation of Casualty	45 – 52
11	Other Topics (Fracture, Types of Bandages, Cardiac Arrest, Drowning, Asphyxia, and foreign body removal in Unconscious casualty)	53 – 65

## **CHAPTER – 1**

### **PRINCIPLES OF FIRST AID**

1. **Definition** First aid is the immediate assistance given to the injured or ill with the available resources before medical help is available.
2. **Aim.** The aims of first aid are :-
  - (a) To save life by removing any danger immediately threatening life.
  - (b) To prevent further injury and deterioration of the patient's condition.
  - (c) To relieve pain.
  - (d) To make medical care available at the earliest.
3. **Qualities of a First Aider.** A good first aider should be :-
  - (a) A good observer.
  - (b) Able to act quickly.
  - (c) Calm and collected.
  - (d) Able to lead and control the crowd, and take help from on-lookers.
  - (e) Self confident and able to judge which injuries need to be tackled first.
  - (f) Able to reassure the apprehensive victim and his/her anxious or nervous relatives by demonstrating competence, expressing sympathy and providing reassurance.
4. **Principles of First Aid.**
  - (a) Remove the patient to a place of safety.
  - (b) Loosen clothing around the neck and waist to aid breathing.
  - (c) Reassure the patient.
  - (d) Look for the following :-
    - (i) Is there any failure of breathing ? If yes, start artificial respiration.
    - (ii) Is there any failure of circulation ? If yes, start external cardiac massage.
    - (iii) Is there severe bleeding? If yes, stop bleeding by pressing firmly on the bleeding area with a clean pad for a few minutes or apply pressure on the pressure areas.
  - (e) Treat shock.

- (f) Relieve pain.
- (g) Avoid handling the casualty unnecessarily.
- (h) Arrange for the safe removal of the casualty to hospital.

### Summary

- (a) Immediate assistance to injured / ill.
- (b) Aim is to save life / prevent deterioration of condition.
- (c) First aider should be a good observer, calm and must act quickly.
- (d) **Principle.** Remove patient to place of safety and administer CPR if required. Seek medical help.

## CHAPTER – 2

### BODY STRUCTURES AND FUNCTIONS

1. The human body can be compared to a well-oiled machine which is required to perform various functions in co-ordination with other systems. As in a machine, coordinated functioning is essential as no particular system can be said to be more important than another.
2. Every first aider should be familiar with the various systems of the body and their functioning so that he can understand and treat any abnormalities in an emergency.
3. **The Skeletal System.**

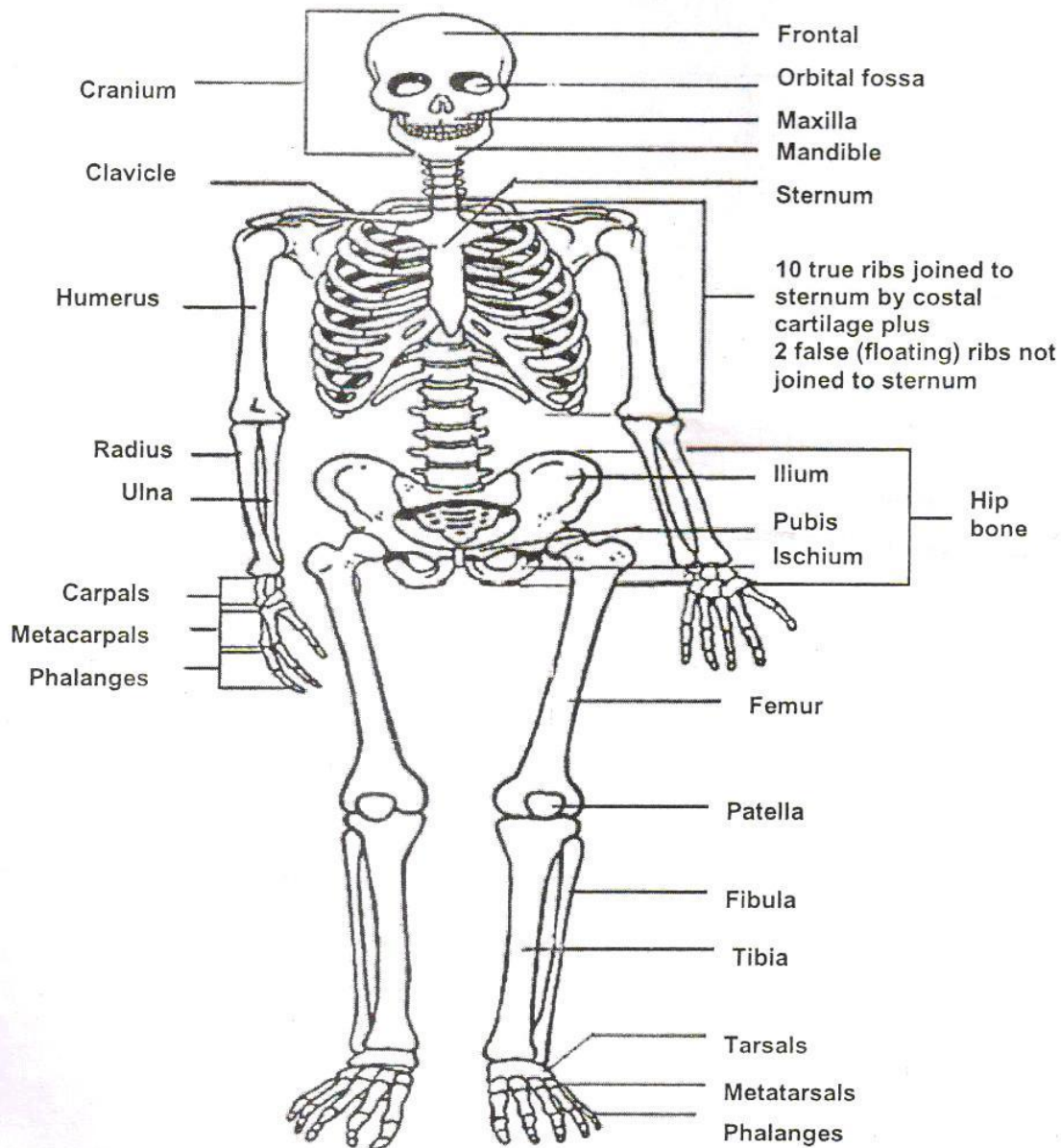

**Fig 1 - Skeletal System**

4. Organs of the Chest and Abdomen (Front).

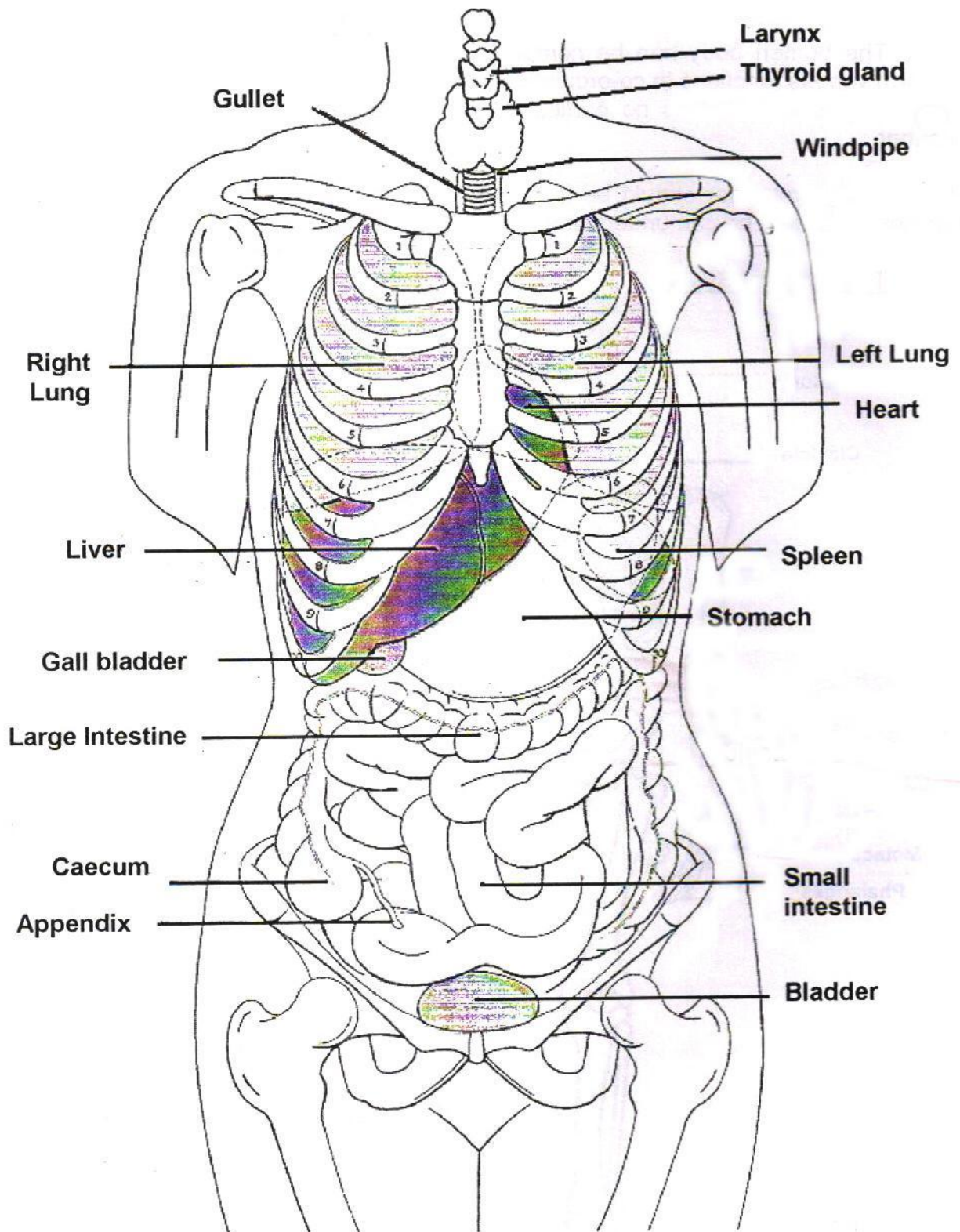

**Fig 2. – Organs of the Chest and Abdomen (Front)**

5. Organs of Chest & Abdomen (Rear).

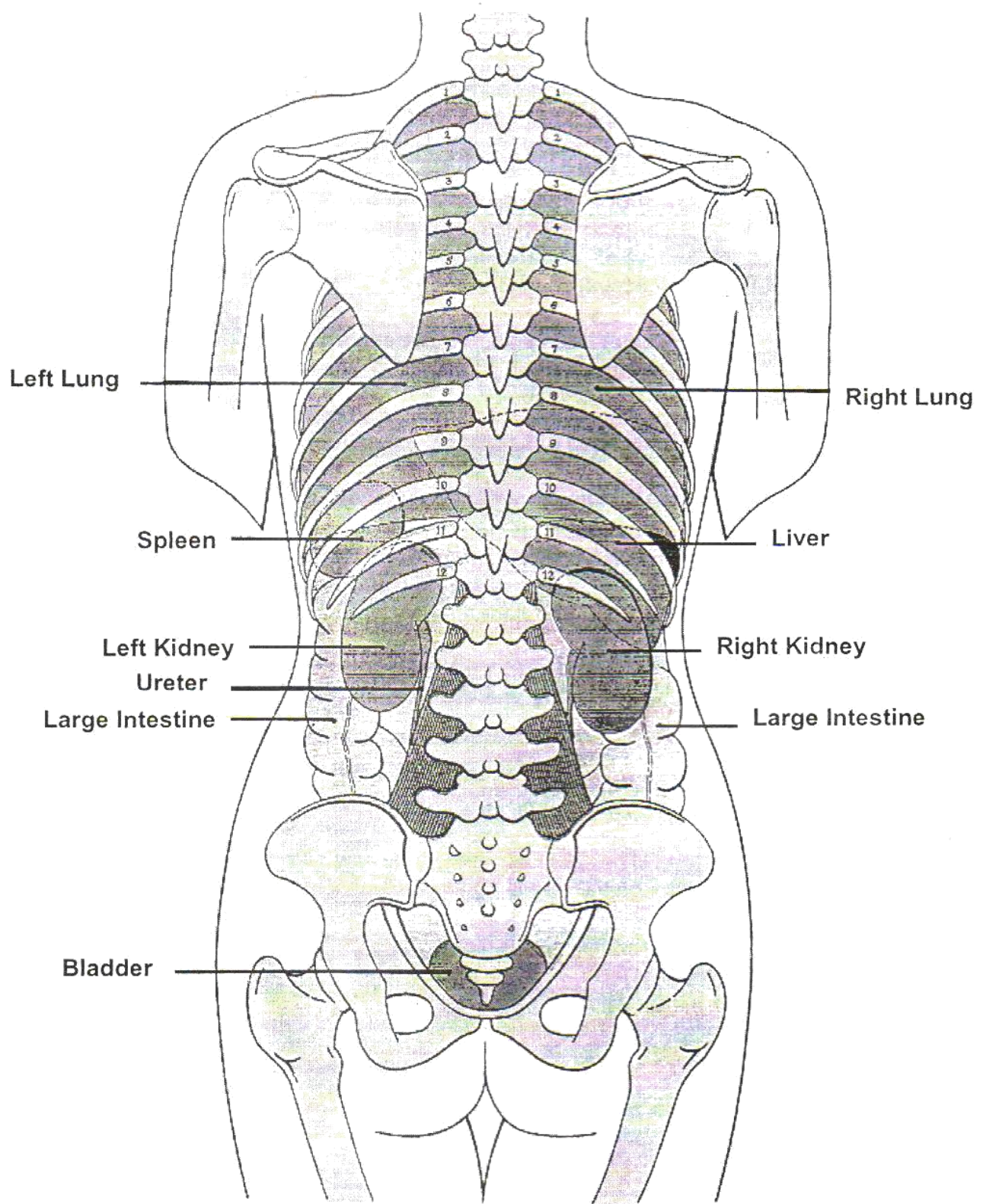

Fig 3 - Organs of Chest & Abdomen (Rear)

## **Body Frame Work**

6. The human body consists of the head, the trunk and the limbs. The frame work of the body consists of the following :-
7. **Skull**. The eight bones of the skull and the fourteen bones of the face are firmly united and incapable of movement. The bone of the lower jaw – the mandible – however, can be moved up and down as well as from side to side.
8. **Back Bone or the Vertebral Column**. It is composed of 33 small bones called vertebrae. There are 7 vertebrae in the neck (cervical vertebrae), 12 in the back (thoracic vertebrae), 5 in the loin (Lumbar Vertebrae) and 5 in the rump (sacrum) and 4 fused together in the vestigial tail (coccyx).
9. **Ribs**. There are 12 ribs on each side, attached to the thoracic vertebrae at the back except the lowest two. These ribs are not attached to the breastbone in front. (Floating ribs).
10. **Breast Bone (Sternum)**. It is a flat bone forming the front of the thoracic cage.
11. **Collar Bone (Clavicle)**. It extends from the sternum, or breast bone, to the shoulder. Two in number, right clavicle and left clavicle.
12. **Shoulder Blade (Scapula)**. It is a thin flat bone forming a part of the shoulder girdle. Two in number, right and left shoulder blades.
13. **Upper Limb Bones**. There is one long bone in each arm – the humerus and two long bones in each fore arm – the radius and the ulna. The wrist has 8 small bones and the hand has 19 bones.
14. **Hip Bone or Innominate Bone**. There are two hip bones attached to the sacrum. Each hip bone is made of 3 bones – ilium, ischium and pubic bone.
15. **Lower Limb Bones**. There is one long bone in each thigh – the femur, two long bones in each leg – tibia and fibula, 7 small bones in the ankle and 19 bones in the foot.
16. **The Joints**. The various bones in the human body are joined to one another by ligaments. The joints may be movable or immovable. Movements between bones may be only in one plane as in the hinge joints at knee and elbow, in all planes as in the ball and socket joint at the shoulder or there may be just a small degree of movement as in the wrist joint.
17. **Muscles**. The bones are covered with muscles. The muscles are attached to the bones and cross over joints, so that when the muscles contract, movement is produced at the joints by bringing the bones together. Since the muscles can be contracted at will, they are called voluntary muscles. They are also called striated muscles because they reveal striations under a microscope. There is another type of muscle called involuntary muscle, which cannot be contracted at will, e.g. muscle in the wall of the bowel, air passages and blood vessels. These are also called smooth muscles because they do not show striations under a microscope. The muscle of the heart is a special type of involuntary muscle known as cardiac muscle.
18. **Skin**. The body is covered by skin, under which lies a layer of fat which act as insulation. The skin protects the underlying tissue from mechanical injury as well as from infections. It maintains body temperature & also functions as an excretory organ by the process of sweating. Skin is also the largest sensory organ for touch, pain, pressure.
19. **Body Cavities**. Various organs in the body are placed in body cavities like the cranial cavity, thoracic cavity, abdominal cavity and pelvic cavity. The cranial cavity is bounded by the skull bones.

Thus the brain inside this cavity is well protected. The thoracic cavity is bounded by the rib cage all around and the diaphragm below. The rib cage is formed by the vertebral column behind, the ribs on the sides and the sternum in front. The thoracic cavity contains the heart, lungs, trachea and bronchi, the esophagus and the major blood vessels draining into the heart and carrying blood away from it. The thoracic cavity expands during inspiration by flaring out of the ribs and downward movement of the diaphragm.

20. The abdominal cavity is bounded by the vertebral column behind and strong voluntary muscles on the sides and front. It contains the stomach, liver, spleen, gall bladder, pancreas, kidneys, small intestine and most of the large intestine.

21. The pelvic cavity is protected by the bones of the sacrum and innominate bones. It contains the urinary bladder, part of the large intestine and the internal reproductive organs.

22. **Organ Systems of the Body.** The organ systems in the body serve various physiological functions.

23. **Nervous System.** The brain is the master organ. It receives information from organs of special sense such as eyes, nose, tongue and skin. It controls movement, interprets sensation, regulates body activities and generates memory and thought.

24. **Cardio Vascular System.**

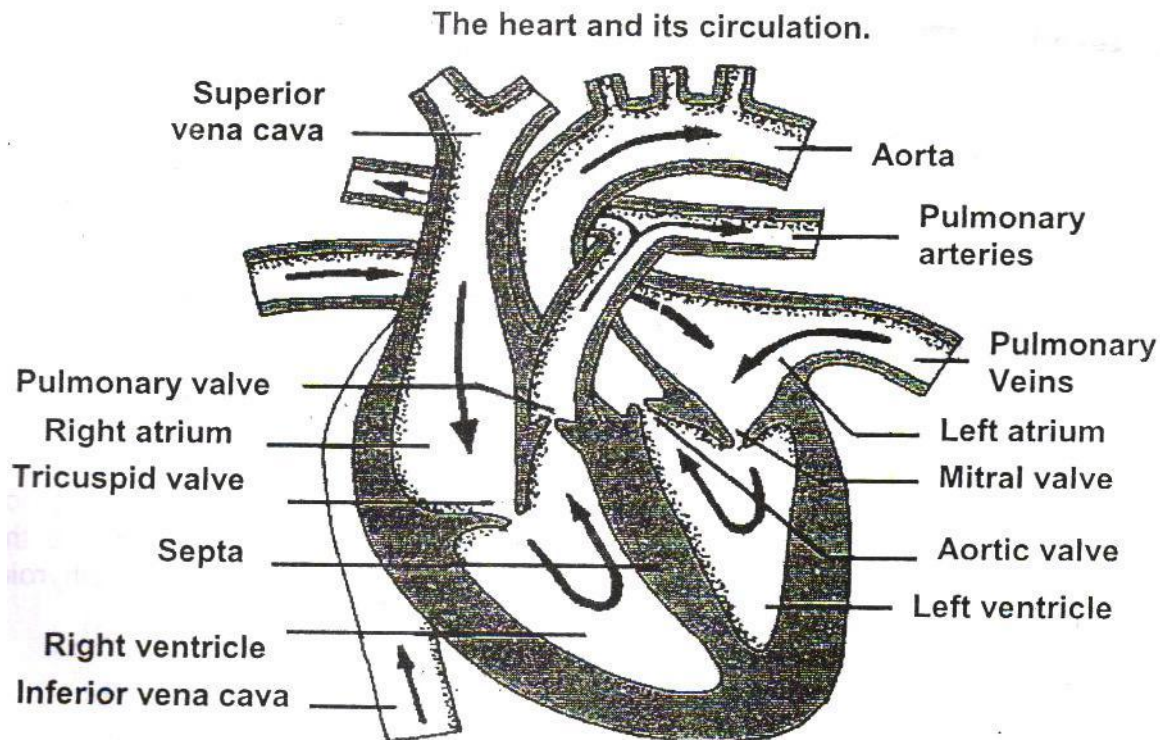

**Fig 4 - Cardio Vascular System**

25. The cardiovascular system is made up of the heart, aorta, superior and inferior vena cava, pulmonary artery, pulmonary veins and the peripheral blood vessels. The heart is of the size and shape of one's closed fist and weighs about 300-350 gms in adults. It has 3 layers, the covering layer called pericardium, middle layer called myocardium and the inner-most layer called endocardium.

26. The heart has 4 chambers. The upper two are called atria and the lower two are called ventricles. There is a valve with three cusps called tricuspid valve between the right atrium and the right ventricle. The valve between the left atrium and the left ventricle has two cusps and is called bicuspid valve or mitral valve.

27. The right atrium receives impure blood from the lower part of the body through inferior vena cava and upper part of the body through the superior vena cava. This blood passes into the right ventricle during the relaxation of the ventricle. From the right ventricle blood is pumped into the lungs through the pulmonary arteries. The blood purified by the lungs returns to the left atrium through pulmonary veins and drains into the left ventricle through the mitral valve during ventricular relaxation. During ventricular contraction the mitral valve closes and blood is pumped into the aorta to be circulated to the body through various arteries.

28. The blood flow in the arteries is pulsatile due to rhythmic contractions of the heart. This is felt as pulse at different sites: the side of the neck – the carotid, on the front of wrist – the radial, at the root of the leg – the femoral, on the back of the knee – the popliteal etc. The normal pulse rate is 70-80 per minute.

29. The pressure generated by the pumping of blood by the heart and the resistance offered by the blood vessels is called blood pressure. It is different during contraction or systole of the heart and relaxation or diastole of the heart and is called systolic and diastolic blood pressure respectively. It is measured by using an instrument called Sphygmomanometer. Normal blood pressure is 120/80 mm of Hg.

### **Digestive System**

30. It is composed of the stomach, the small intestine, the large intestine, the rectum and the glands, which secrete digestive enzymes into the gastro intestinal tract – the salivary glands, liver and pancreas.

### **Urinary System**

31. It consists of the kidneys, ureters, urinary bladder and urethra. It is involved in the removal of chemical waste from the blood and helps to balance water and salt levels of the blood by excreting urine.

### **Endocrine System**

32. It consists of a number of glands which secrete various hormones into the blood stream which help to regulate body activities and functions. The pituitary gland is the master gland which controls the activity of other glands, such as thyroid, parathyroid, adrenal and sex glands or gonads – testis and ovary.

### **Reproductive System**

33. It consists of the gonads, reproductive tract and the hormones needed for sexual reproduction.

### **The Respiratory System**

34. The respiratory system is composed of lungs and the respiratory track consisting of the nose, naso-pharynx, the larynx, the trachea or the wind pipe, the bronchi and bronchioles. The bronchioles finally break into small sacs called alveoli which are surrounded by pulmonary capillaries. Gaseous exchange between the inspired air in the alveoli and the impure blood in the capillaries occurs at this level. The lungs are covered by a sac called pleura. The inside of the sac is smooth and filled with a

thin layer of fluid to allow expansion of lungs without friction. When thorax expands, the lungs expand and air is drawn into the alveolus which is known as inspiration. With collapsing of the thorax to the original size, the air is thrown out, called expiration. The normal respiratory rate is 16-20 per minute in adult. It is more rapid in children being 40 per minute in a new born baby and 30-32 per minute at the age of 5. The ratio of respiratory rate to pulse rate is 1:4.

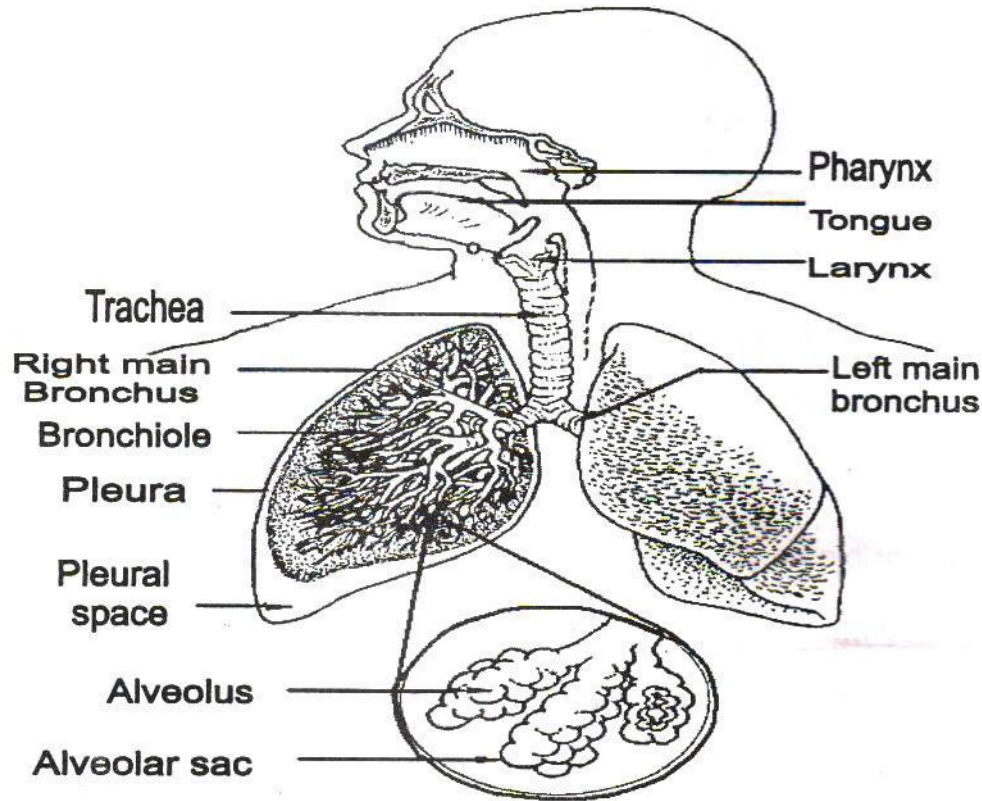

**Fig. 5 Respiratory System**

35. **Immune System.** It protects the body from disease causing organisms.
36. **Special Sense Organs.** Special sense organs receive all stimuli and transmit them to the brain through nervous system. These organs are :-
- (a) Eyes
  - (b) Ear
  - (c) Tongue
  - (d) Nose
  - (e) Skin

## SUMMARY

1. The human body comprises of various body systems working in co-ordination as summarized in the following paragraphs.
2. **Skeletal Muscular System.**
  - (a) Consists of all bones, joints and muscles.
  - (b) Responsible for movement.
3. **Nervous System.**
  - (a) Controlled by the brain.
  - (b) Integrates all inputs from sense organs and body functions.
4. **Cardiovascular System.**
  - (a) Comprises of heart and the blood vessels.
  - (b) Responsible for pumping blood and oxygen to all body tissues.
5. **Respiratory System.**
  - (a) Consists of respiratory track and lungs.
  - (b) Responsible for gaseous exchange in the body.
6. **Digestive System**
  - (a) Consists of esophagus, stomach, small intestine, large intestine & rectum.
  - (b) Responsible for obtaining energy from digestion.
7. **Endocrine System.**
  - (a) Consists of various glands.
  - (b) Secrete hormones which regulate body functions.
8. **Urinary System.**
  - (a) Consists of kidneys, ureters, urinary bladder & urethra.
  - (b) Helps in removal of waste and in maintaining salt water balance.
9. **Reproductive Ssystem.** Consists of male & female gonads and reproductive tract.
10. **Immune System.** Helps body fight diseases.

## **CHAPTER – 3**

### **CASUALTY**

#### **1. Immediate Actions in Case of Casualty.**

- (a) Gain access to the patient in the easiest and the fastest way.
- (b) Look after your own safety, do not become the next casualty.
- (c) Observe the accident scene and assess the situation.
- (d) If necessary remove the casualty from danger or remove danger from casualty.
- (e) If necessary direct others to direct traffic, keep bystanders at a safe distance, make essential telephone calls, send for help and inform master.
- (f) Turn off all engines that may still be running.
- (g) Find out whether the casualty is unconscious, conscious, alive or dead.
- (h) Identify the disease or condition from which the casualty is suffering.
- (i) Give immediate, appropriate and adequate first aid measures to a casualty. Give priority to casualty with severe bleeding, absent pulse or breathing and loss of consciousness.
- (j) Should bear in mind that a casualty may have more than one injury and that some casualties will require more urgent attention than others.
- (k) If the casualty is in an enclosed space do not enter the enclosed space unless you are a trained member of a rescue team acting under instructions.
- (l) The rescue team must not enter unless wearing breathing apparatus which must also be fitted to the casualty as soon as possible.
- (m) The casualty must be removed quickly to the nearest safe area outside the enclosed space unless his injuries and the likely time of evacuation make some treatment essential before he can be removed.
- (n) Arranging without delay for shifting of the casualty to a doctor or to a hospital in such a manner as not to worsen the injury in transit.
- (o) Keep a record of the patient, his condition, the incidence and witnesses.
- (p) Once a first aider has started the care he should not leave the scene or stop the care until a qualified and responsible person relieves him.

#### **2. Things to Remember.**

- (a) First aider should keep in mind that he is not a doctor.
- (b) He should not open wounds which have already been bandaged by somebody else.
- (c) He should not declare any person dead. Only a doctor is qualified to declare death.
- (d) Perform proper transportation techniques.

### 3. Signs & Symptoms

(a) **Signs.** These are noted by the first aider's examination such as temperature, pulse, blood pressure, tenderness, respiration, bleeding (type and volume), wounds, foreign bodies, colour of face, swelling, deformity, bruising, reflexes, responses to touch and sound, type of vomitus if any, loss of memory, inability to move limbs, burning, smell of gas and alcohols etc. The normal values of the vital signs are as follows :-

(i)	Temperature	-	98.4°F (37°C)
(ii)	Pulse Rate	-	70 – 80 /minute
(iii)	Respiratory Rate	-	16 – 20 /minute
(iv)	Blood Pressure	-	120/80 mm Hg.

(b) **Symptoms.** These are the sensations experienced by the casualty or obtained by asking him questions directly, viz. is there is pain, loss of normal movement, loss of sensation, feeling of cold, heat, thirst, nausea, dizziness, numbness etc.

## CHAPTER – 4

### POSITIONING OF CASUALTY

1. The patient is nursed in different positions in different situations. The commonly used positions are described in the succeeding paragraphs.

#### Recovery Position

2. A patient who is unconscious, if breathing and has got heart beat should be nursed in recovery position.

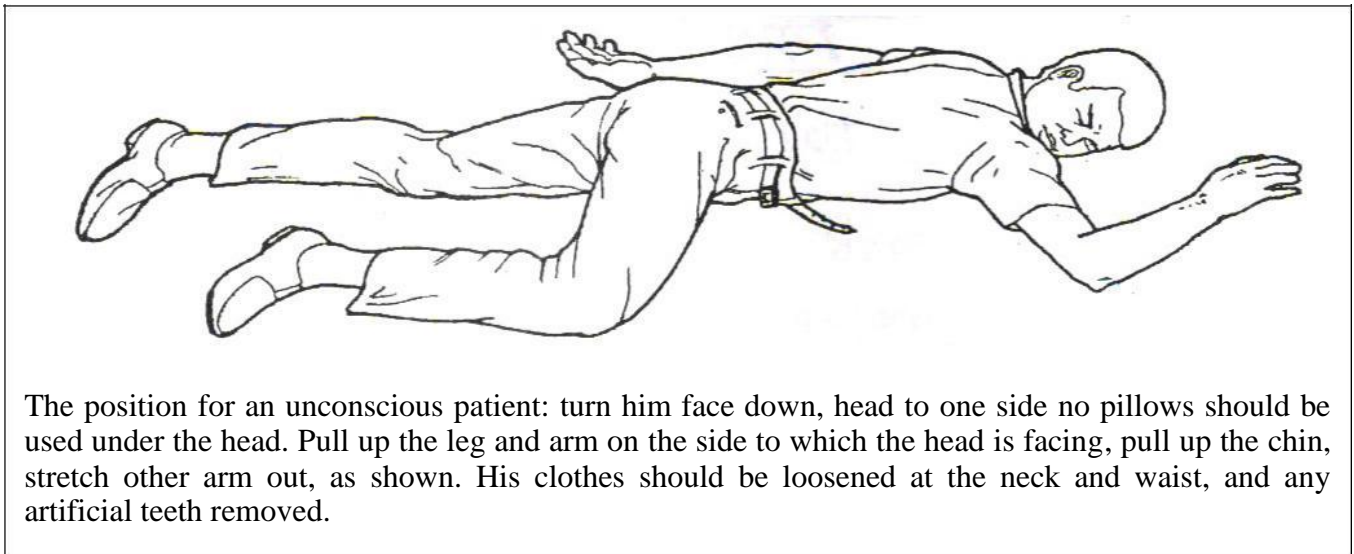

**Fig. 6 – Recovery Position**

3. **Advantages of Recovery Position.**

- (a) It maintains an open airway.
- (b) Tongue cannot fall to the back of the throat.
- (c) Head and neck remain in an extended position so that the air passage remains wide and any vomiting or other secretion from the mouth drain freely.

4. **Recovery Position cannot be used.**

- (a) When there are fractures to the upper or lower body.
- (b) When the casualty is lying in a confined space or if it is not possible to bend the limbs.

### Prone Position

5. A patient is placed on his abdomen with head turned to one side. A pillow is placed under the head and the hands are kept on the sides. This position is used for :-

- (a) Burns of the back.
- (b) Wounds of the back.

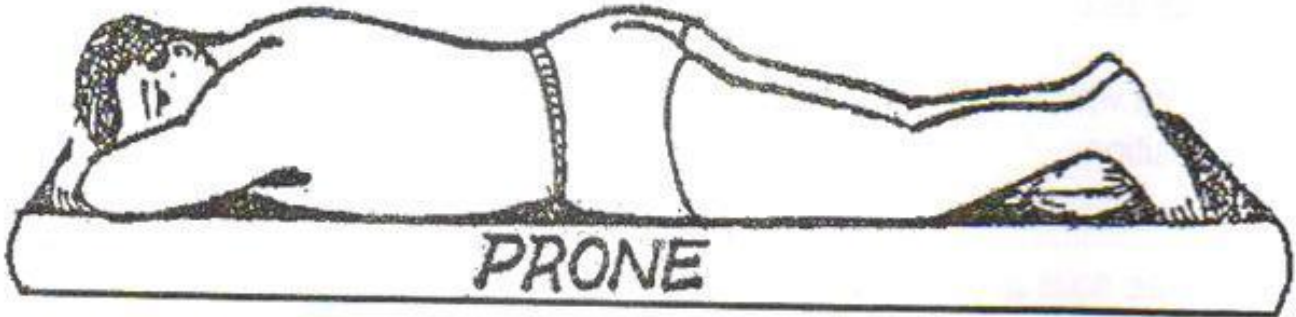

**Fig. 7 – Prone Position**

### Supine Position with Legs Raised

6. This position is used when a patient is in shock. Lay the casualty on the back and turn the head to one side. Raise the legs with 2 pillows to improve blood supply to the heart. If the victim has a fracture in the lower limb, it should not be elevated unless it is well splinted.

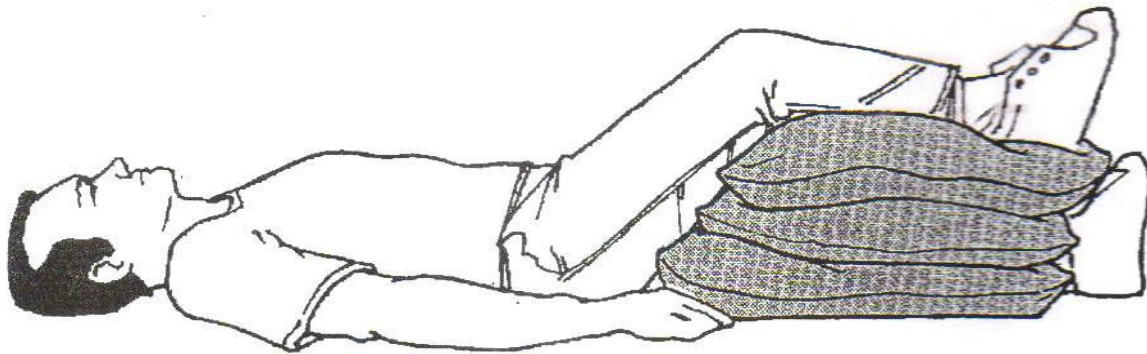

**Fig. 8 – Supine Position with Legs Raised**

### Fowler's Position

7. When a patient is having difficulty in breathing, this position is used. The patient is kept in a sitting position with the help of 3-4 pillows.

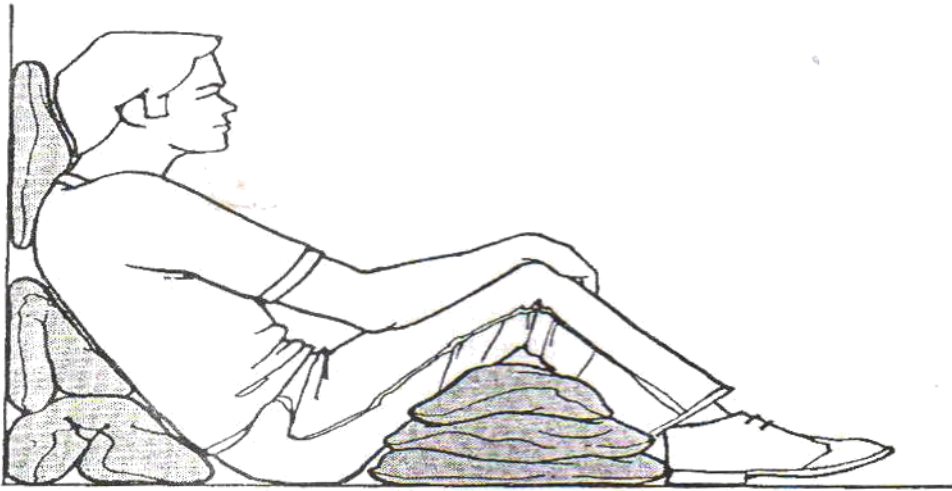

**Fig. 9 – Fowler’s Position**

**Dorsal Recumbent Position**

8. The patient is kept on his back. A pillow is placed under the head. The hands are kept on both the sides. It is used for examination of the patient. This position without pillow is used in case of fracture of the spine and also to give CPR.

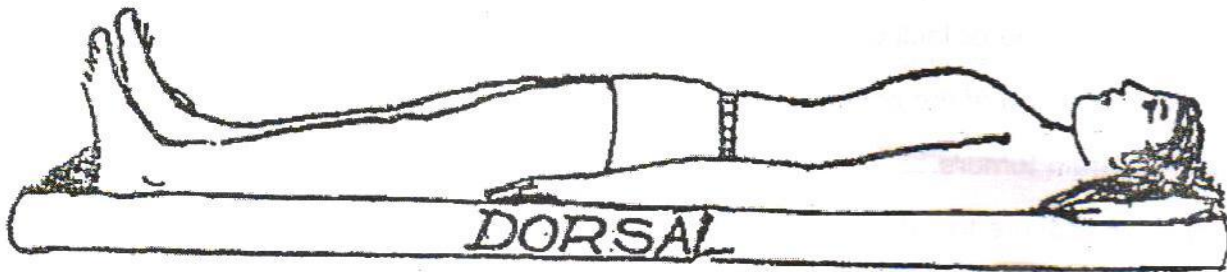

**Fig. 10 – Dorsal Recumbent Position**

**Summary**

<b><u>Position of Casualty</u></b>	
(a) Recovery Position	– Unconscious casualty
(b) Prone Position	– Burn/Wounds of the back
(c) Supine Position with legs raised	– Position in Shock
(d) Fowlers Position	– Difficulty in breathing
(e) Dorsal recumbent	– CPR and Fracture of spine Position.

## CHAPTER – 5

### UNCONSCIOUS CASUALTY

#### Definition

1. Unconsciousness is a state of complete loss of consciousness and the casualty is totally unresponsive to any painful stimulus. He is unaware of the surroundings and his body muscles are in a complete state of relaxation.

- (a) Unconsciousness is due to interference with the functions of the brain.
- (b) Seriousness can be determined by testing the casualty's response to stimuli such as sound or touch or pain.

#### 2. Causes of Unconsciousness

- (a) Brain injuries.
- (b) Fits or convulsions.
- (c) Syncope or lack of cerebral circulation.
- (d) Infection of the coverings of the brain or tissues of brain.
- (e) Brain tumors.
- (f) Exposure to extreme cold.
- (g) Exposure to extreme heat.
- (h) Severe infections.
- (i) Severe injuries.
- (j) Severe burns.
- (k) Drug reaction.
- (l) Electric shock.
- (m) Failure of liver or kidney.
- (n) Poisoning with chemical gas or alcohol.
- (o) Severe heart attack.
- (p) Drowning.
- (q) Diabetes or over dose of insulin.
- (r) Severe bleeding or fluid loss.

### **Levels of Responsiveness**

3. These are the stages through which person may pass during progression from consciousness to unconsciousness or vice versa.

- (a) Stage I – He may respond normally to questions & conversations.
- (b) Stage II – He answers direct questions.
- (c) Stage III – He responds vaguely to questions.
- (d) Stage IV – He obeys commands.
- (e) Stage V – He responds to pain only.
- (f) Stage VI – He does not respond at all.

### **4. First Aid Management**

- (a) Maintain the airway open.
- (b) See that there is a free supply of fresh air and that the air passage is free of any obstruction.
- (c) Take the casualty away from harmful gases, if any or if inside a room open doors and windows.
- (d) Remove any loose dentures or detached teeth and clear the casualty's mouth of any vomit or blood.
- (e) Correct the tongue, which might have fallen back.
- (f) Loosen any tight clothing around neck, chest and waist.
- (g) Keep the casualty warm but do not over heat him.
- (h) Keep back the crowds, they only obstruct.
- (i) If breathing has stopped or about to stop, put the person on hard surface in supine position or flat position and start artificial respiration immediately.
- (j) Listen to the heart sounds and feel pulse at wrist and neck. Pulse at the neck can be felt by placing the tips of the two fingers of one hand into the groove between the windpipe and the large muscles at the side of the neck.
- (k) Check the pupils of the eyes to see if they are dilated or constricted. When the heart stops beating the pupils stay dilated and do not react to light.
- (l) Start heart compression at once without wasting time if the heart has stopped, as delay in restoring blood flow will damage the brain and the person can die within 4-5 minutes.
- (m) Watch continuously for any changes in the condition of pulse, respiration and level of responsiveness.

- (n) If pulse & respiration is restored, then place the person in recovery position.
- (o) Turn casualty face down with head to one side. No pillow should be placed under the head. See figure 11.
- (p) Do not leave the casualty until he is handed over to medical authorities.
- (q) Nothing should be given orally till consciousness returns.
- (r) Remove the under lying cause of unconsciousness.
- (s) Restore breathing and heart beat.
- (t) Control bleeding, if any.
- (u) Remove poisons.
- (v) Prevent any further injuries to the patient.
- (w) Do not treat any unconscious casualty as a minor case.

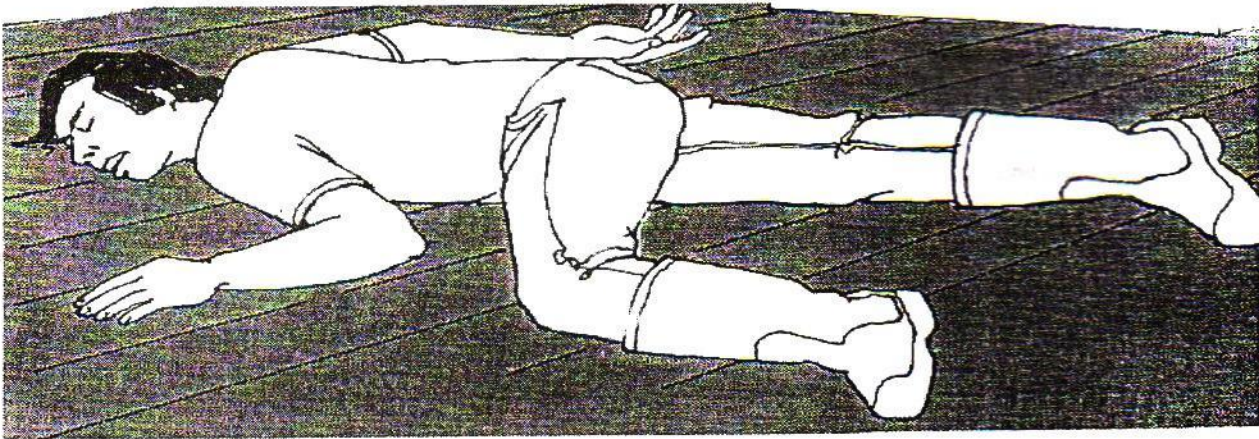
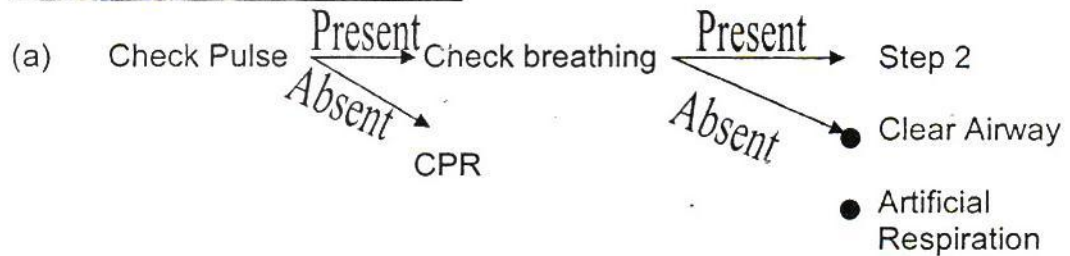

**Fig. 11 – Unconscious Position**

## Summary

### Unconsciousness

#### 1. First Aid in Unconsciousness



(b) Head to toe examination

(c) First aid for the cause

(d) Check vital signs

(e) Warm clothing

(f) Fluid-Intravenous(if indicated)

(g) Recovery position

(h) Transport on stretcher

## CHAPTER – 6

### CARDIO PULMONARY RESUSCITATION (CPR) BASIC LIFE SUPPORT

#### Introduction

1, Basic life support or CPR is an emergency life saving procedure that consists of recognizing and correcting failure of the respiratory or cardiovascular systems. Any profound disturbance of the airway, breathing or circulation can promptly produce brain death.

2. Basic life support comprises the ABC steps which concerns the airway, breathing and circulation respectively. Its prompt application is indicated in :-

- (a) A – Airway obstruction.
- (b) B – Breathing or respiratory arrest.
- (c) C – Circulatory or cardiac (heart) arrest.

3. Basic life support requires no instruments or supplies, and the correct application of the steps for dealing with the above three problems can maintain life until the patient recovers sufficiently to be transported to a hospital, where he can be provided with advanced life support. It must be undertaken with maximum sense of urgency and any inadequacy or absence of breathing or circulation must be determined immediately.

- (a) If breathing alone is inadequate or absent all that is necessary is either to open the AIR WAY or to apply ARTIFICIAL RESPIRATION.
- (b) If circulation is also absent artificial circulation must be started through HEART COMPRESSION, in combination with artificial respiration.
- (c) If breathing stops before the heart stops, enough oxygen will be available in the lungs to maintain life for several minutes. However, if the heart arrest occurs first, delivery of oxygen to the brain ceases immediately.
- (d) Brain damage is possible if the brain is deprived of oxygen for 4-6 minutes. Beyond 6 minutes without oxygen, brain damage is very likely.
- (e) Once you have started basic life support do not interrupt it for more than 5 seconds for any reason, except when it is necessary to move the patient, even in that case, interruption should not exceed 15 seconds each.

4. **A B C of CPR** – (Steps)

- (a) A for Airway – Clearance.
- (b) B for Breathing – Assist in breathing
- (c) C for Circulation – Establish circulation.

5. **STEP – A (Airway)**

- (a) Establish an open airway.
- (b) Place the person in the face up position on a hard surface.
- (c) Put one hand under the patient's neck & the other hand on the forehead.
- (d) Lift the neck with one hand, and apply pressure to the forehead with the other to tilt the head backward.
- (e) This extends the neck and moves the base of the tongue away from the back of the throat.
- (f) The head should be maintained in this position during the entire artificial respiration and heart compression procedure.
- (g) If the airway is still obstructed with any foreign material in the mouth or throat, it should be removed immediately with the fingers.
- (h) Once the airway has been opened, the patient may or may not start to breathe again.
- (i) To assess whether breathing has returned, the person providing the basic life support must place his ear about 2-3 cm above the nose and mouth of the patient.
- (j) If the rescuer can feel and hear the movement of air, and can see the patient's chest and abdomen move, breathing has returned.
- (k) With airway obstruction, it is possible that there will be no air movement even though the chest and abdomen rise and fall with the patient's attempt to breathe. Also, observing chest and abdominal movement is difficult when the patient is fully clothed.

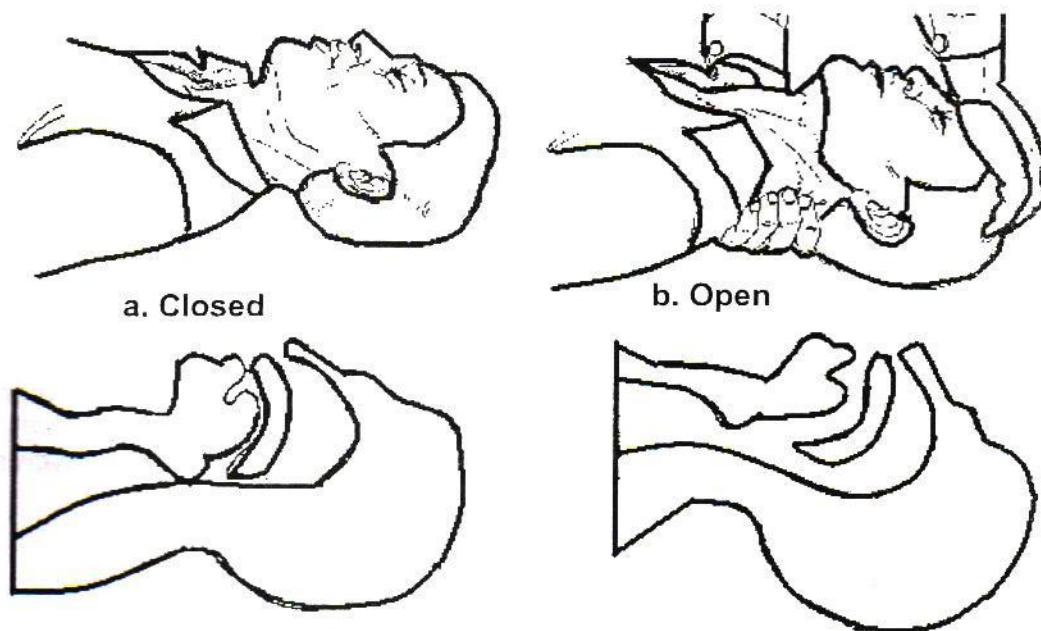

**Fig. 12 – Steps a Ariway**

## **STEP – B (Breathing)**

6. If the patient does not resume adequate, spontaneous breathing promptly after his head has been tilted backward, then artificial respiration should be given by the mouth to mouth or mouth to nose method or with other techniques. Regardless of the method used the preservation of an open airway is essential.

### 7. **Mouth to Mouth Respiration**

- (a) Keep the patient's head at a maximum backward tilt with one hand under neck.
- (b) Place the heel of the other hand on the forehead with the thumb and index finger toward the nose.
- (c) Pinch together the patient's nostrils with the thumb and index finger to prevent air from escaping.
- (d) Continue to exert pressure on the forehead with the palm of the hand to maintain the backward tilt of the head.
- (e) Take a deep breath and then form a tight seal with your mouth over and around the patient's mouth.
- (f) Blow two quick, full breaths in first without allowing the lungs to deflate fully.
- (g) Watch the patient's chest while inflating the lungs. If adequate respiration is taking place, the chest should rise and fall.
- (h) Remove your mouth and allow the patient to exhale passively. If you are in the right position, the patient's exhalation will be felt on your cheek.
- (i) Take another deep breath, form a tight seal around the patient's mouth, and blow into the mouth again.
- (j) Repeat this procedure 10-12 times a minute (once every five seconds) for adults and children over four years of age.
- (k) If there is no air exchange and an airway obstruction exists, remove obstruction with fingers and resume artificial respiration.

### **Mouth to Mouth Respiration using Disposable Flange.**

8. Due to the knowledge and awareness about transmission of communicable disease like AIDS through saliva and abraded skin one resorts to safer methods of mouth to mouth respiration with a sterile disposable flange as shown in fig. 13 to avoid contact with saliva.

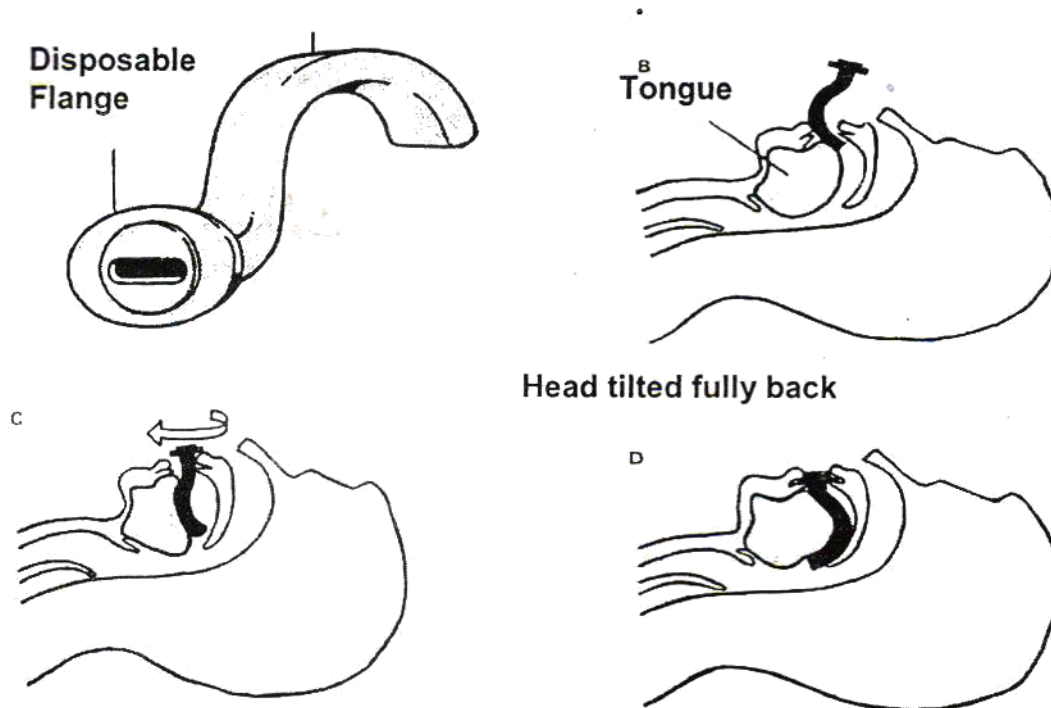

**Fig. 13 – Respiration with Disposable Flange**

**STEP – C (Heart Compression)**

9. In attempting to bring back to life a non breathing person whose heart has stopped beating, heart compression (external cardiac compression) should be applied along with artificial respiration.

10. **Techniques for Heart Compression.** Compression of the sternum produces some artificial ventilation, but not enough for adequate oxygenation of the blood. For this reason, artificial respiration is always required whenever heart compression is used.

- (a) Effective heart compression requires sufficient pressure to depress the patient's lower sternum about 4-5 cms (in an adult).
- (b) For chest compression to be effective, the patient must be on a firm surface. If he is in a bed, a board or improvised support should be placed under his back. However, chest compression must not be delayed by a search for a firmer support.
- (c) Kneel close to the side of the patient and place the heel of one hand over the lower half of the sternum.
- (d) Avoid placing the hand over the tip of the breast bone, which extends down over the upper abdomen as pressure on the lower end may tear the liver and lead to severe internal bleeding.
- (e) Feel the tip of the sternum and place the heel of the hand about 4 cm from the head end of the patient.

- (f) Place the heel of the other hand on top of the first one.
- (g) Your fingers must never rest on the patient's ribs during compression, since this increases the possibility of rib fracture.
- (h) Rock forward so that your shoulders are almost directly above the patient's chest.
- (i) Keep your arms straight and exert adequate pressure almost directly downwards to depress an adult's chest for 4-5 cms. (Lower part of sternum).
- (j) Compress the chest 60 times per minute for an adult, as this is enough to maintain blood flow and slow enough to allow the heart to fill with blood.
- (k) The compression should be regular, smooth and uninterrupted, compression and relaxation being of equal duration.
- (l) Under no circumstances should compression be interrupted for more than five seconds.

11. **Heart Compression with Two First Aiders.**

- (a) It is preferable to have two rescuers because artificial circulation must be combined with artificial respiration. (Figure 13 & 14 page 33).
- (b) The most effective artificial respiration and heart compression are achieved by giving one lung inflation quickly after each five heart compression (5:1 ratio). The compression rate should be 60 per minute if two rescuers are operating.
- (c) One rescuer performs heart compression, while the other remains at the patient's head, keeps it tilted back and continues artificial respiration.

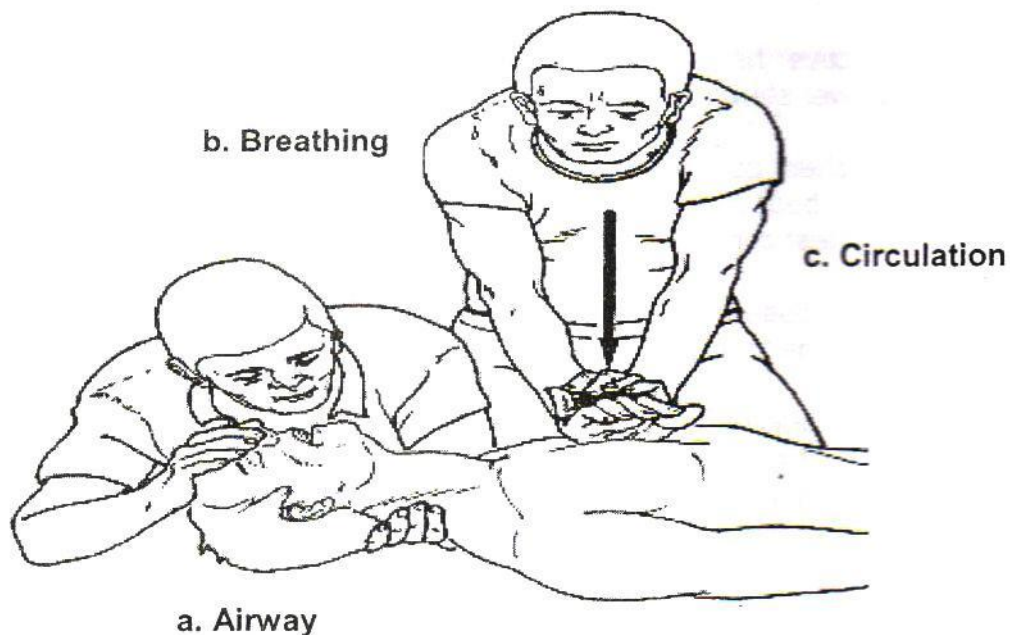

**Fig. 14 – Heart Compression Two First Aiders**

12. **Heart Compression with Single First Aiders.** A single rescuer has to perform both artificial respiration and artificial circulation using 30:2 ratio. Two very quick lung inflation should be delivered after each 30 chest compressions, without waiting for full exhalation of the patient's breath.



**Fig. 15 – Heart Compression with Single First Aiders**

- (a) A rate of 100 chest compression per minute must be maintained by a single rescuer in order to achieve 50-60 actual compressions per minute, because of interruptions for the lung inflations.
- (b) Single rescuer should give two lung inflation after 30 cardiac compressions (30:2).

13. **Checking Effectiveness of Heart Compression.**

- (a) Check the reaction of the pupils. If the pupils contract when exposed to light this is a sign that the brain is receiving adequate oxygen and blood.
- (b) Carotid (neck pulse) should be felt after first minute of heart compressions and artificial respiration and every five minutes there after. The pulse will indicate the effectiveness of the heart compression.
- (c) Return of colour of skin.
- (d) Return of spontaneous heart beat.

## Sylvester Method

14. The Sylvester method is an alternative method of artificial respiration. It is particularly recommended for patients who have swallowed poisons.

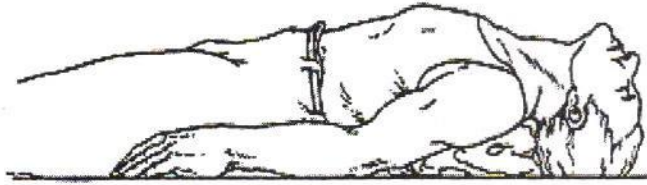

(a) Lay the patient on his back on a firm surface.

(b) Raise his shoulders on a cushion or folded jacket, or in some other way.

**Firm Surface**



(c) Kneel astride the patient's head. If necessary, turn his head to one side to clear out the mouth.

(d) Grasp his wrists and cross them over the lower part of his chest.

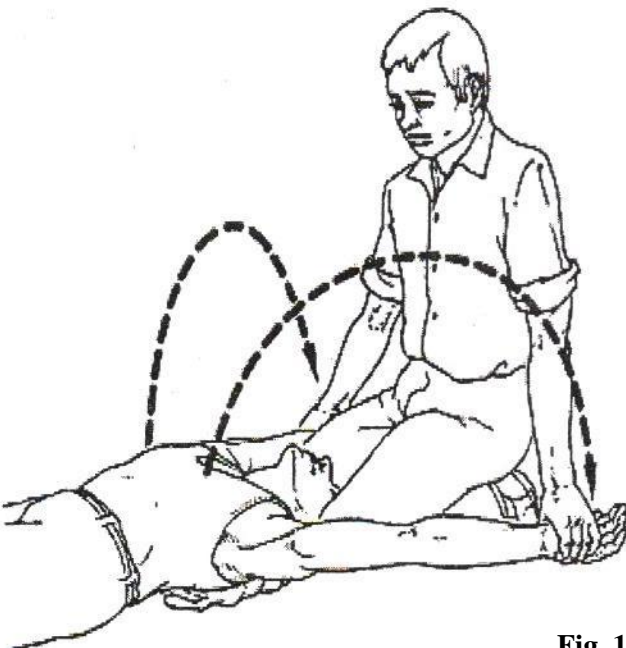

(e) Rock your body forward and press down on the patient's chest. Release the pressure and with a swooping movement, draw the patient's arms backwards and outwards as far as possible.

(f) Repeat this procedure rhythmically (twelve times per minute) Keep the mouth clear.

**Fig. 16 – Sylvester Method**

## Summary

### Resuscitation

#### 1. Airway.

- (a) Airway Clearance
- (b) Maintain open airway.

#### 2. Artificial Respiration.

- (a) Kneel beside patient, extend neck, pinch nostrils.
- (b) Take a deep breath, blow into the patients mouth, watch for chest expansion.
- (c) Feel carotid pulse.
  - (i) If present, continue artificial respiration at a rate of one breath every 4-5 seconds.
  - (ii) If absent, start chest compression.

#### 3. Chest Compression.

- (a) Locate lower half of breastbone.
- (b) Give compression at center of the lower half of sternum. Depress sternum by 4-5 cms.
- (c) Complete 30 compressions at a rate of 100 /min. (less than 2 compression per second.)
  - (i) Single Operator - 30 chest compression : 2 mouth to mouth breaths.
  - (ii) Two Operators - 5 chest compressions: 1 mouth to mouth breath.
  - (iii) CPR - Cardio Pulmonary Resuscitation.
  - (iv) ABC - Airway Breathing Circulation.

## CHAPTER – 7

### BLEEDING

#### Introduction

1. The human body contains approximately 5 litres of blood. A healthy adult can lose up to half a litre of blood without harmful effects, but the loss of more than this can be threatening to life.

#### Definition

2. Bleeding (Haemorrhage) is an escape of blood from the blood vessels or bleeding is a flow of blood from an artery, vein or capillary.

#### Effects of Bleeding (Haemorrhage)

3. Haemorrhage from major blood vessel of the arms, neck and thigh may occur so rapidly and extensively that death occurs in a few minutes. So haemorrhage must be controlled immediately to prevent excessive loss of blood.

- (a) The loss of red blood cells causes a lack of oxygen to the body systems.
- (b) A decrease in blood volume causes a decrease in blood pressure.
- (c) The heart's pumping rate increases to compensate for reduced blood pressure.
- (d) The force of the heart beat is reduced since there is less blood to pump.

#### Types of Bleeding

4. There are three different types of haemorrhage or bleeding :-

- (a) **Arterial Bleeding.**
  - (i) Blood is bright red in colour.
  - (ii) It spurts at each contraction of heart.
  - (iii) Flow is pulsatile.
- (b) **Venous Bleeding.** Bleeding is from the veins, which carries impure blood to heart.
  - (i) Blood is dark red in colour.
  - (ii) It does not spurt.
  - (iii) Steady flow of blood.

(b) **Capillary Bleeding.**

- (i) Blood is red in colour.
- (ii) It does not spurt.
- (iii) Slow but even flow.

**External and Internal Bleeding.**

5. Bleeding may occur externally following an injury to the outside of the body or internally from an injury in which blood escapes into tissue spaces or the body cavity.

6. **External Bleeding.** If the bleeding is from the surface of the body it is called external bleeding.

- (a) Evidence of major external blood loss.
- (b) Symptoms and signs of shock.
  - (i) Casualty complains of thirst.
  - (ii) Blurring of vision.
  - (iii) Fainting and giddiness.
  - (iv) Face and lips become pale.
  - (v) Skin feels cold.
  - (vi) Pulse becomes faster but weaker.
  - (vii) Restlessness and sweating
  - (viii) Breathing becomes shallow
  - (ix) Unconsciousness.

7. **Internal Bleeding.** If the bleeding is with in the chest skull or abdomen etc., it is called internal bleeding. This can not be seen immediately but later the blood may ooze out through the nose or ear or coughed up from the lungs or vomited from stomach.

- (a) History of sufficient injury to cause internal bleeding.
- (b) Wounds that have penetrated the skull.
- (c) Wounds that have penetrated chest or abdomen.
- (d) History or Medical condition, which may cause internal bleeding, like ulcer etc.
- (e) Pain and swelling around the affected area.
- (f) Signs of shock.

- (g) Blood may appear from one of the body orifices as nose, ear, mouth, rectum, urethra, vagina etc.

### **External Bleeding Management**

8. **First Aid Management.** The aim is to :-

- (a) Control bleeding as soon as possible.
- (b) Keep the wound clean and dress it to minimize blood loss and to prevent infection.

9. **General Management**

- (a) Place the person in such a position that he/she will be least affected by the loss of blood.
- (b) Lie the person down and raise his legs in semi flexed position.
- (c) Control the bleeding.
- (d) Maintain airway.
- (e) Prevent the loss of body heat by putting blankets under and over the person.
- (f) Keep him at rest, as movement will increase heart action, which causes the blood to flow faster and perhaps interfere with clot formation.

### **Specific Management of External Bleeding.**

10. **Minor Bleeding.**

- (a) Wash your hands before dealing with a wound.
- (b) If the wound is dirty lightly rinse it with running water if available.
- (c) Protect the wound with clean cloth and clean the surrounding skin with soap and water if available and make it dry.
- (d) Dress a small wound with a Band-Aid after local disinfection.
- (e) Raise and support the injured part unless you suspect an underlying fracture.
- (f) If the wound is larger than apply unmedicated dressing or gauze or clean pad and bandage firmly in position.
- (g) If in doubt seek medical help.

11. **Major External Bleeding.** There are Four Method to Control External Bleeding.

- (a) **Direct Pressure.** Do not waste your time hunting for dressing. Place your hand directly over the wound and apply pressure. Keep applying firm and steady pressure. If the wound is large then squeeze the edges together.

- (i) If dressing is available then apply or with a clean cloth apply pressure until bleeding has stopped. This may take 10-30 minutes or longer.
  - (ii) Tie the bandage firmly enough to control bleeding but not so tight as to cut off circulation.
  - (iii) Never replace any dressing once it is in place.
  - (iv) If dressing is soaked with blood place another dressing directly over the blood soaked dressing and hold with in place with firm pressure.
  - (v) Immobilize or support the injured part.
- (b) Elevation. Raise the bleeding part of the body above the level of the heart so that the flow of blood will slow down in that part and clotting will speed up.

12. **Pressure Points.**

- (a) Arterial bleeding can be controlled by thumb or finger pressure applied at the pressure points. (Figure 18).
- (b) Pressure points are the places where arteries are close to the skin.
- (c) Pressing the artery against the underlying bone can control flow of blood to the injured part.

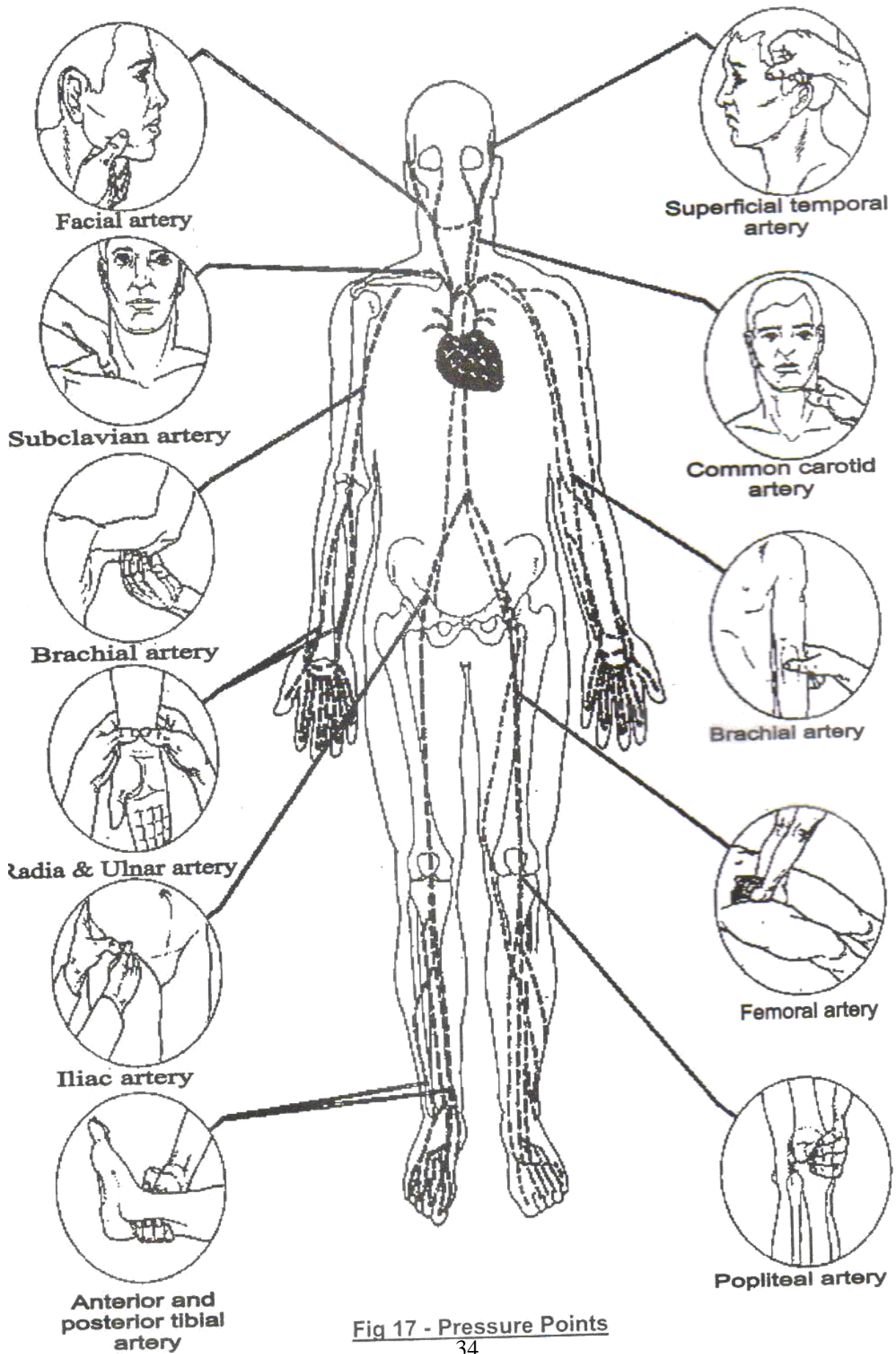
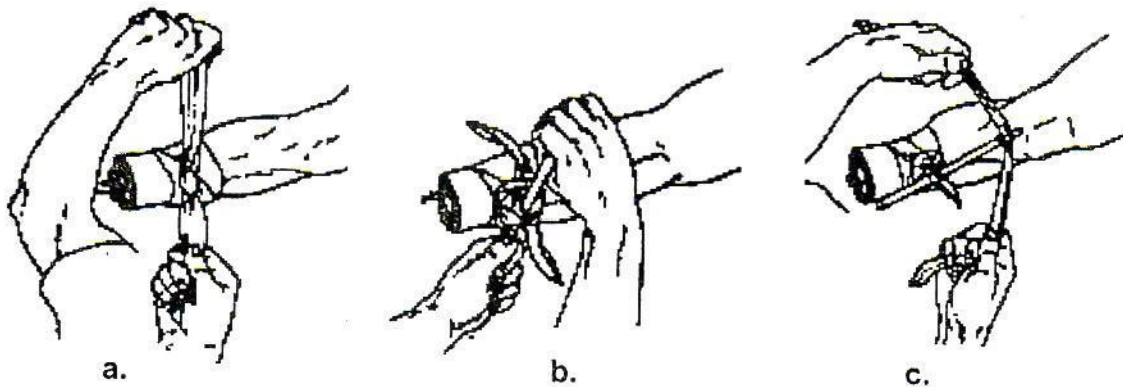

Fig 17 - Pressure Points

13. **Applying a Tourniquet.**

- (a) A tourniquet is a strip of rubber or cloth used to control severe bleeding.
- (b) It should be used only for severe life threatening bleeding that can not be controlled by other means.
- (c) It can be used only in upper and lower limbs.



**Fig. 19 – Applying and Securing a Tourniquet**

**Internal Bleeding Management**

14. **First Aid.**

- (a) Asses the cause of internal bleeding.
- (b) Keep the person down with head low and to one side to ensure blood supply to the brain.
- (c) If conscious, advise person not to move.
- (d) If condition allows raise his legs gently to aid return of blood flow to the vital organs.
- (e) Loosen any constricting articles and clothing around neck chest and waist.
- (f) Monitor pulse rate, breathing rate, blood pressure temperature and levels of consciousness.
- (g) If breathing rate and pulse rate cannot be monitored start cardio – pulmonary resuscitation.
- (h) Shift to sick bay and start oxygen imhalation and intravenous fluids with the help of the master of the ship.
- (i) Raise foot end of the bed to minimize shock.
- (j) Keep monitoring the vital parameters whilst master sends RMA (Radio Medical Advice) and arranges for evacuation of casualty immediately as an emergency stretcher case.

- (k) Keep the patient warm.
- (l) Do not apply hot water bottles or ice bags to chest or abdomen.
- (m) If conscious even do not give anything to eat or drink as he may have to undergo immediate surgery.

### Summary

#### Bleeding

1. External Bleeding.
  - (a) Minor Bleeding - Clean Wounds Dressing
  - (b) Major Bleeding - Direct pressure, Elevation, Pressure on Pressure points, Tourniquet, Treat shock.
  
2. Internal Bleeding.
  - (a) CPR
  - (b) Treat Shock
  - (c) Evacuate.

## **CHAPTER – 8**

### **MANAGEMENT OF SHOCK**

#### **What is Shock ?**

1. Shock is a state of inadequate tissue perfusion. In other words, it is a state in which the amount of oxygen and nutrients being delivered to the cells are decreased.
2. Shock is the result of a decrease in the vital functions of various organs of the body that results from a decrease in effective circulating oxygenated blood or fluid in the body as a result of injury or illness.

#### 3. **Effects of Shock.**

- (a) It can vary from faintness to complete collapse.
- (b) Early loss of consciousness that mainly involves the nervous system and that may be fatal.
- (c) Progressive loss of blood from active circulation which may lead to failure of heart out put and insufficient oxygen to cells that are vital for survival.
- (d) Continuous lowering of blood pressure which may lead to kidney and liver failure.

#### 4. **Causes of Shock.**

- (a) Severe or extensive injuries.
- (b) Severe pain
- (c) Heart attack
- (d) Bleeding (internal or external bleeding)
- (e) Severe burns which leads to loss of body fluids.
- (f) Electrocutation
- (g) Exposure to extreme heat and cold
- (h) Drugs or allergic reactions
- (i) Poisoning from drugs, gases and other chemicals and also from alcohol intoxication.
- (j) Emotional up set due to good or bad news.
- (k) Stress and fright.
- (l) Bites or stings of poisonous snakes or insects.

## Types of Shock

5. **Nervous Shock.** Nervous shock is due to strong emotional upset that is fear, pain, good or bad news. It may also result from spinal or head injury resulting in loss of nerve control or loss of control of nervous system.
  
6. **Haemorrhagic Shock.** Due to loss of blood from external or internal bleeding or loss of blood/fluid due to wounds, multiple injuries or severe burns, severe vomiting and loose motions.
  
7. **Cardiogenic Shock.** Cardiac muscles not pumping effectively due to injury or previous heart attack, the damaged heart muscles no longer imparts sufficient pressure to circulate the blood.
  
8. **Bacterial or Septic Shock.** Severe infection, discharge of poisons or toxins into the blood caused by bacteria, toxin causes pooling of blood in capillaries with dilatation of vessels and not enough blood remains available for tissues.
  
9. **Anaphylactic Shock.** It is a severe allergic reaction of the body to some drugs or foreign protein to which the person is sensitive. It causes dilatation of blood vessels and loss of blood in the surrounding area.
  
10. **Electric Shock.** Due to electrocution or high voltage electric current. If any part of the body comes in contact with a live wire who is exposed and not covered by insulator or with a cable or rail in which current is leaking a person gets an electric shock.
  
11. **Symptoms.** These are sensations experienced by casualty or obtained by asking him or observers questions.
  - (a) Casualty is anxious and restless.
  - (b) Weakness, fainting or giddiness and disorientation.
  - (c) The skin is pale, cold and often moist but later it may develop a bluish, ashen colour.
  - (d) Shallow, rapid or gasping breathing.
  - (e) Nausea, vomiting and extreme thirst.
  - (f) Unconsciousness
  - (g) Weak and rapid pulse
  - (h) Blood pressure falls
  - (i) Pupils are dilated
  - (j) Evidence of associated external or internal injury.

12. **Signs.** These are recorded by first aider.
- (a) Type of bleeding or injury
  - (b) Recording of vital parameters (temp. pulse resp. and B.P.)
  - (c) Assessment of levels of consciousness
  - (d) Color of face
  - (e) Presence of swelling / bruises / deformities.
  - (f) Responses to touch / verbal commands.
  - (g) Loss of memory
  - (h) Palpation of affected systems / injures
  - (i) Preparation for first aid

### **First Aid Treatment**

13. **Conscious Patient.**
- (a) Reassure and comfort the casualty when conscious.
  - (b) Remove the causes of shock, this includes controlling bleeding, restoring breathing and relieving severe pain.
  - (c) Loose any tight clothing to help the circulation and assist breathing.
  - (d) Keep the patient warm but do not over heat.
  - (e) Check breathing rate, pulse rate and level of consciousness and evacuate as early as possible.
14. **Unconscious Casualty.**
- (a) Keep the person in recovery position.
  - (b) If breathing and heart beat stops then, clear and establish an airway, begin mouth to mouth respiration with chest massage.
  - (c) Administer fluids (intravenous), liquids should not be given by mouth if the patient is unconscious and having any injuries to chest and abdomen.
  - (d) Remove to hospital immediately.
  - (e) Transport as stretcher case maintaining the right position.

15. **Do Not.**

- (a) Do not apply a hot water bottle as this will increase the blood flow to the vessels of the skin and take it away from the vital organs.
- (b) Do not move the casualty unnecessarily as this will increase shock.
- (c) Do not give the casualty any thing by mouth as it will prevent or delay the surgery.
- (d) Do not give alcohol.
- (e) Do not let the casualty smoke.

**Summary**

**Shock First Aid**

1. **Conscious Casualty.**

- (a) Reassurance
- (b) Supine Position with legs raised
- (c) Control bleeding, Splint fractures
- (d) Warm clothing
- (e) Fluids – Oral or intravenous
- (f) Transport on stretcher

2. **Unconscious Casualty**

- (a) A B C
- (b) Control bleeding, splint
- (c) Recovery position
- (d) Warm clothing
- (e) Fluids – intravenous
- (f) Transport on stretcher

## CHAPTER – 9

### BURNS, SCALDS AND ACCIDENTS CAUSED BY ELECTRICITY

1. Burns and Scalds are dangerous because not only can they cause death, but delayed effects like scarring and deformity can be quite distressing. Hence, prompt and correct treatment of burns and scalds are essential.

- (a) Burns are the injuries that result from dry heat like :-
  - (i) Fire
  - (ii) Contact with hot metals
  - (iii) Chemicals --> Nitric acid, Sulphuric acid, Ammonia, Caustic soda etc.
  - (iv) Electricity & Radiation
- (b) Scalds are injuries caused by moist heat like boiling water, steam, oil, hot tar and and hot liquids. The result of the burns and scalds are same.
- (c) **Shock.** Shock develops because plasma leaks out of circulatory system into the burnt area.
- (d) **Infection.** There is big risk of infection with burns because skin is damaged and there is no protection against micro organisms.

2. **Severity of Burns.** Severity of burns can be assessed by the following :-

- (a) **Depth of Tissues Involved :-**

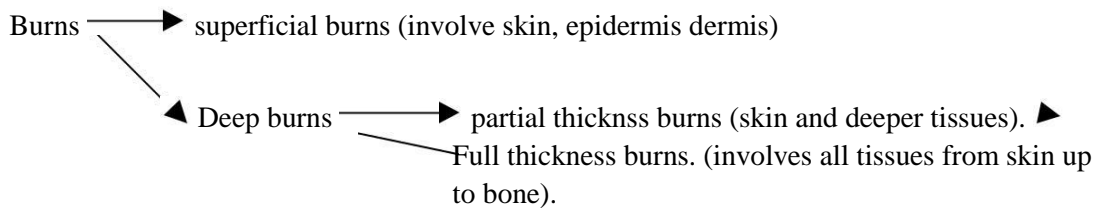

- (b) **Surface Area of Skin Involved.** Using rule of '9' – Distribution of percentage of burns taking in to consideration the surface area of the body involved in the burn.

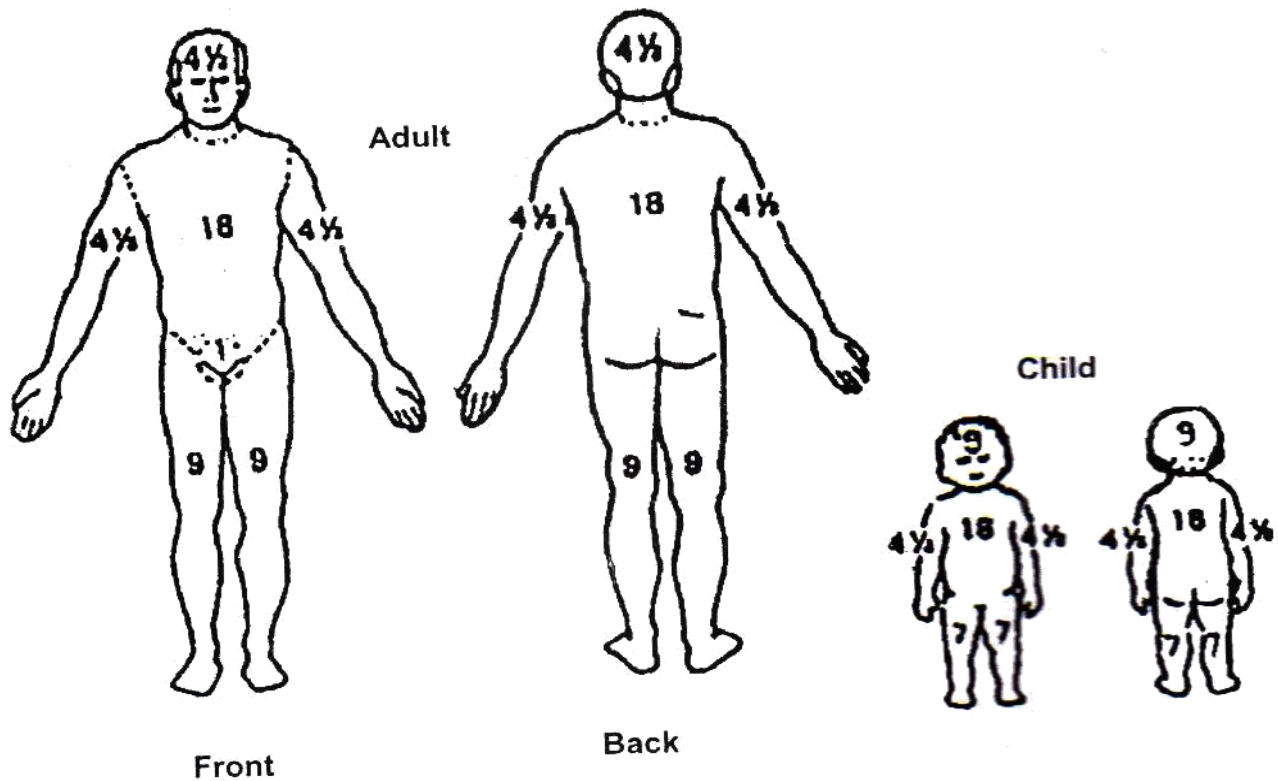

**Fig. 20 – Classification of Burns**

- |        |                          |       |
|--------|--------------------------|-------|
| (i)    | Front of face attributed | 4 ½ % |
| (ii)   | Back of face             | 4 ½ % |
| (iii)  | Upper arm                | 4 ½ % |
| (iv)   | Under surface of arm     | 4 ½ % |
| (v)    | Upper torso              | 9 %   |
| (vi)   | Lower torso              | 9 %   |
| (vii)  | Upper back               | 9 %   |
| (viii) | Lower back               | 9 %   |
| (ix)   | Front of thigh & leg     | 9 %   |
| (x)    | Back of thigh & leg      | 9 %   |
| (xi)   | Crotch                   | 1 %   |
- (c) Clearly illustrated in fig. 20.
- (d) Calculation is lower in a child.
- (e) Any burn over 30 % should be hospitalized in priority.

### 3. **First Aid Management**

- (a) Put out the fire by pouring in water or wrapping in a blanket or rug. Do not allow the person on fire to run about especially into fresh air.
- (b) Immerse the burnt part in cold water, using a bucket, a bowl, a kitchen sink or hold the affected area under running cold water. Keep the part in cold water for 15-20 minutes or until the pain disappears. If that is not possible soak clean cloth in cold water and put it over the burnt area. It needs to be changed frequently. Application of cold water removes residual heat from tissues and prevents further damage.
- (c) Cover burnt area with sterile dressing or freshly laundered linen. Avoid exposure to air. In case of burns over face, make the dressing in the shape of a mask, with holes at the level of the nose for breathing.
- (d) Remove rings, bracelets, shoes and any other tight fitting article as swelling may develop later on making it difficult to remove them.
- (e) Arrange for immediate transfer to hospital.
- (f) Give plenty of fluids to drink, if patient can tolerate.
- (g) When large areas are damaged pack ice in a clean towel and apply it to the burnt area during transfer to a hospital.
- (h) Do not put oil, lotions or ointments on the burnt area.
- (i) Do not pull away burnt clothing stuck to the body.
- (j) Do not handle or touch the patient than absolutely necessary.
- (k) Always check for A, B, C and level of consciousness.

### **Chemical Burns**

- 4. In chemical burns the damage continues as long as the chemical remains in contact with skin.
  - (a) Remove the contaminated clothing carefully after soaking in water. Take care not to contaminate yourself.
  - (b) Flood the affected area with water thoroughly and systematically for 10-15 minutes. One may use soda bicarbonate solution to wash acid burns and vinegar to wash alkali burns before washing with water antidotes.
  - (c) Give general care.

### **Electric Burns**

5. Electrical injuries are due to the effect of high tension electric current or atmospheric electricity as in lightning. The heat generated during passage of current through the body causes deep burns at the exit and entrance of the current.

6. In case of DC shock, patient remains stuck to the source of electricity until the current is broken, hence the damage is extensive. In case of AC shock, the damage is less. There may be physical injury when the patient falls down. The electrical current can disturb the respiratory center and the cardiovascular center causing respiratory arrest and cardiac arrest respectively. Damp clothing, damp foot wear and damp ground increase electrical conductivity and make the damage worse. The patient may be in shock. The measures should be taken are :-

- (a) Switch off the current and remove the plug from the socket.
- (b) If the patient is lying in water keep out of it yourself; as water is an excellent conductor of electricity. For the same reason do not hold the patient under the armpits.
- (c) If the patient is in contact with a live wire, the current in which cannot be switched off, separate the wire from the patient using a long wooden stick and while standing on a nonconductor of electricity like a wooden board or a pile of newspapers. Wear rubber gloves, if available.
- (d) Give artificial respiration and external cardiac massage, if necessary.
- (e) Treat shock if present.
- (f) Treat burns
- (g) Give fluids to drink.
- (h) Arrange for medical aid.

### Summary

#### 1. Burns

- (a) CPR if necessary (Extensive burns)
- (b) Immerse in cold water for 15 minutes.
- (c) Cover with a sterile gauze.
- (d) Elevate limb and immobilize
- (e) Treat for shock
- (f) Treat for pain.
- (g) Give frequent sips of water.
- (h) Do not prick blister.
- (i) Do not pull away clothing stuck to the skin.
- (j) Do not apply ointment / cream.

## CHAPTER – 10

### RESCUE & TRANSPORTATION OF CASUALTY

1. The removal of a sick or injured person either from the site of an accident or ashore is a matter of importance, since his life may depend on the arrangements made.

2. **General Principles to be Observed While Transporting a Patient.**

- (a) Arrest severe haemorrhage, treat shock, splint fracture securely and cover wounds before moving the patient.
- (b) Support the injured part well while moving the patient.
- (c) Do not allow the patient with shock, haemorrhage, or head injury to walk even if the patient is conscious.
- (d) During transportation, close and constant observation of the casualty condition should be done.
- (e) Transportation must be safe, steady and speedy.

3. **Method.** Method of transportation depends upon various factors.

- (a) Number of helpers available.
- (b) Modes of transportation
- (c) Type of injury
- (d) Distance to be covered
- (e) Nature of the route to be covered

4. **Carriage by One Bearer.**



Fig 21 - Cradle

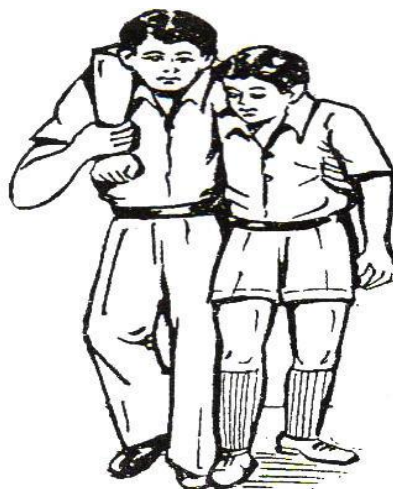

Fig 22 - Human Crutch

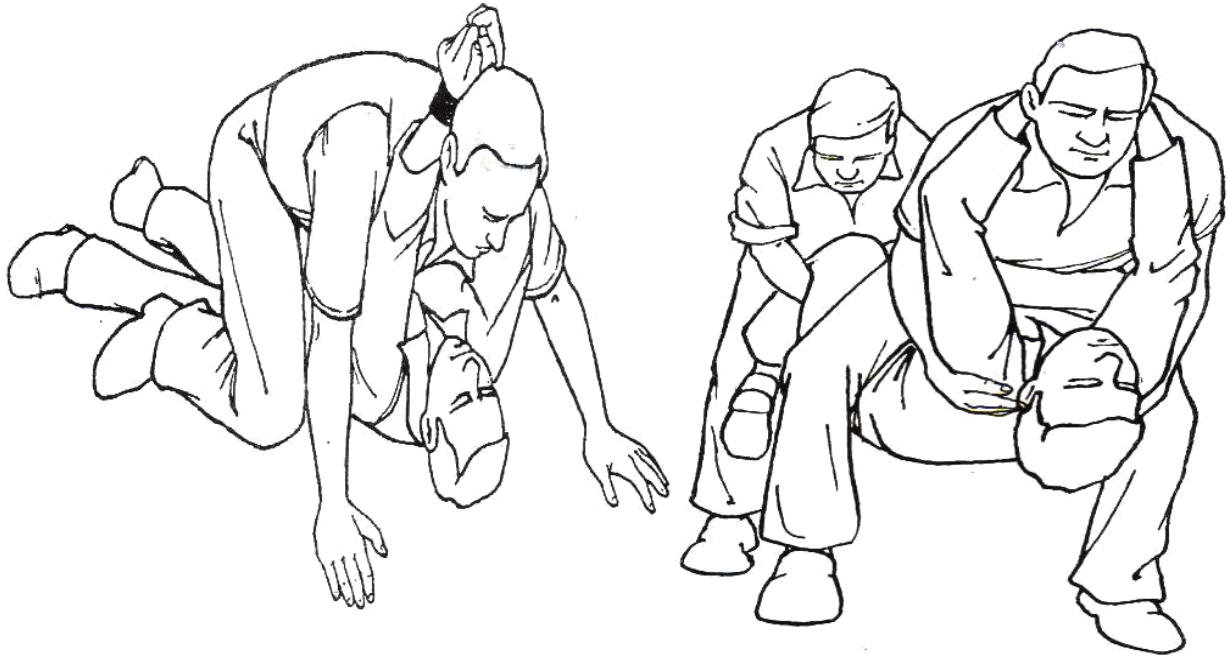

Fig 23 - Neck Drag Method



Fig 24 - Pick a Back

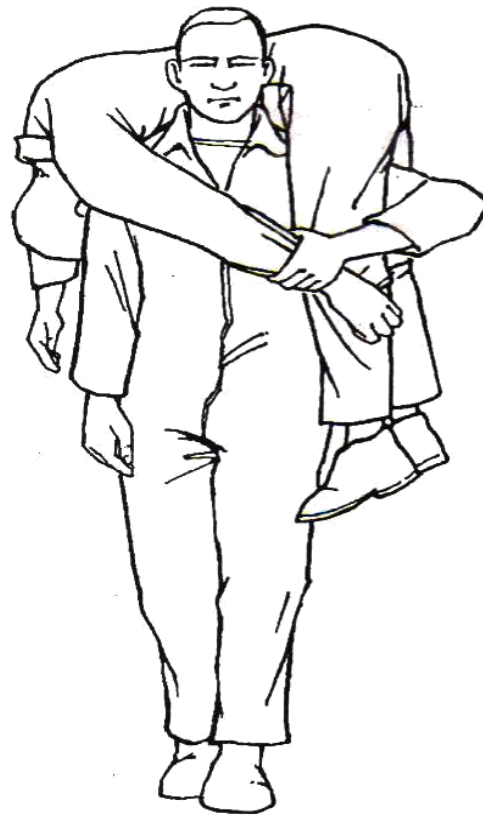

Fig 25 - Fireman's Lift and Carry



**Fig 26 - Two Handed Seats**



**Fig 27 - Three Handed Seats**

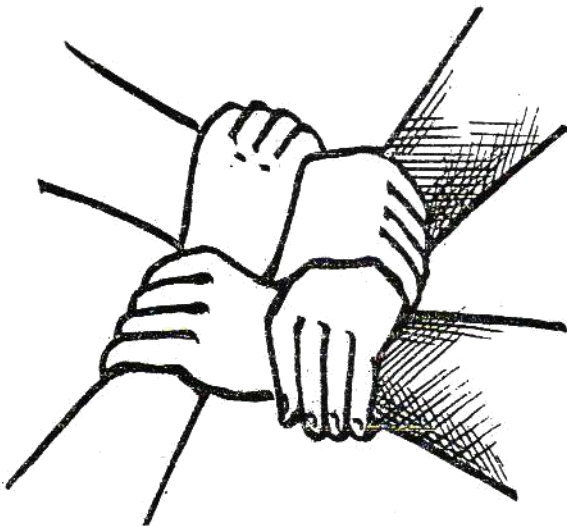

**Fig. 28 – Four Handed Seats**

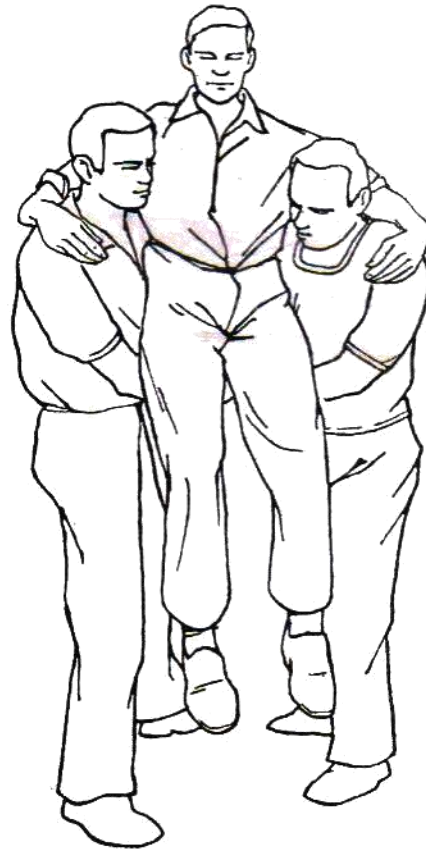



**Fig 29 - Fore and Aft Method**



**Fig. 30 - The Kitchen Chair Carry**

5. **Carriage by Stretchers**

- (a) Ambulance stretchers
- (b) Improvised stretchers with coat, blankets, poles, ground sheet, bedding, sacks and web belt etc.
- (c) Scoop stretcher.
- (d) Neil Robertson stretcher.

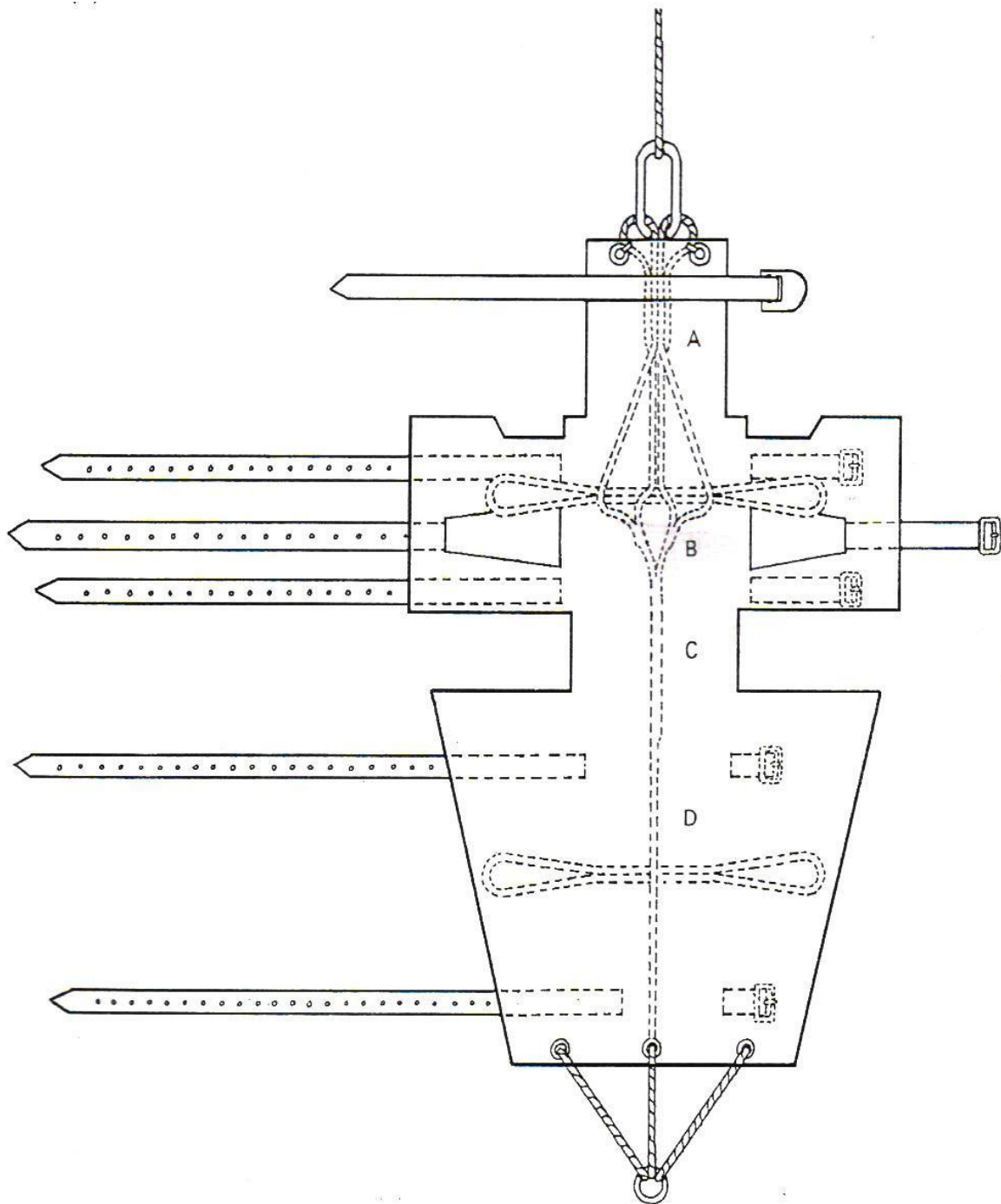

**Fig. 31 – Neil Robertson Stretcher**

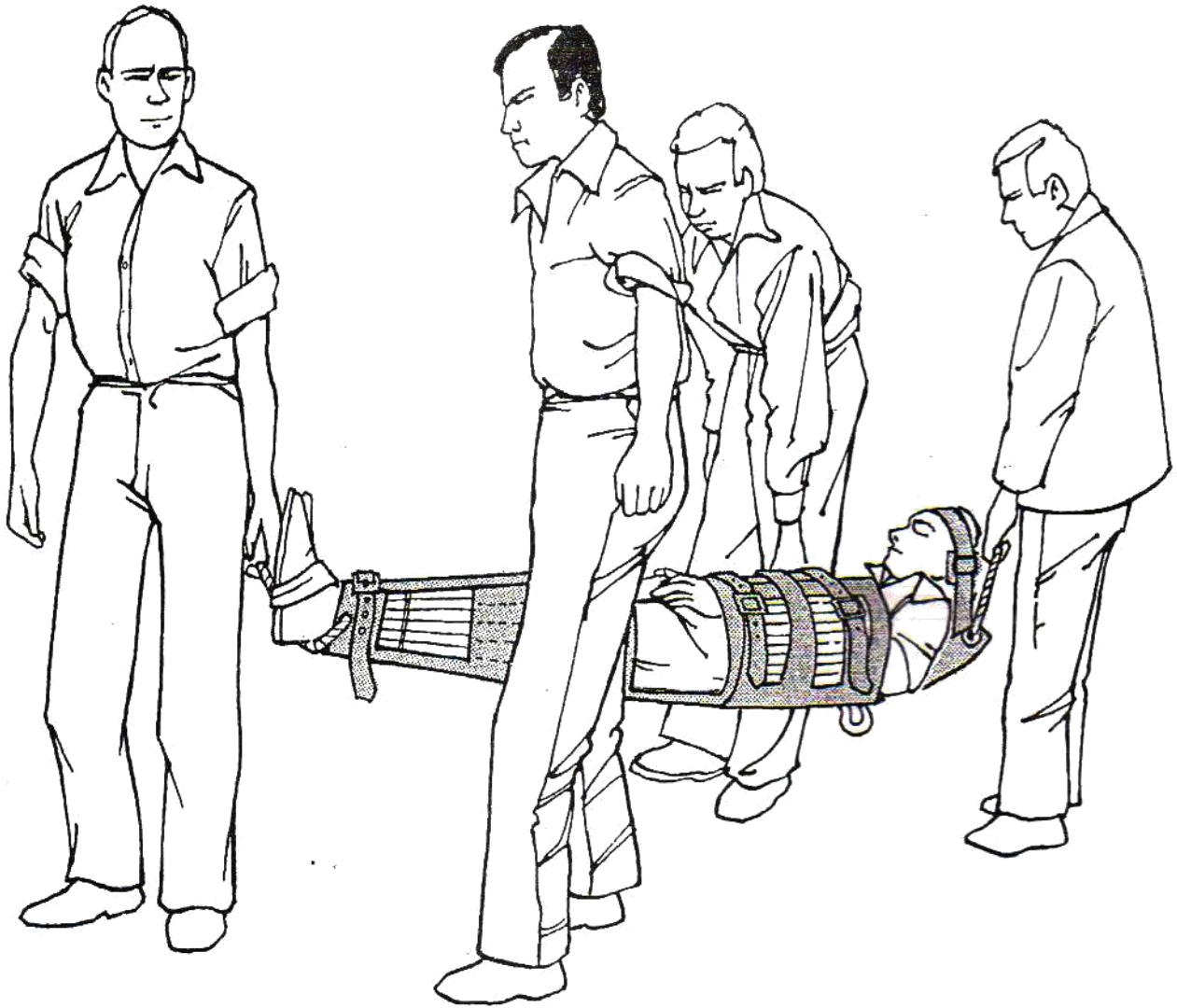
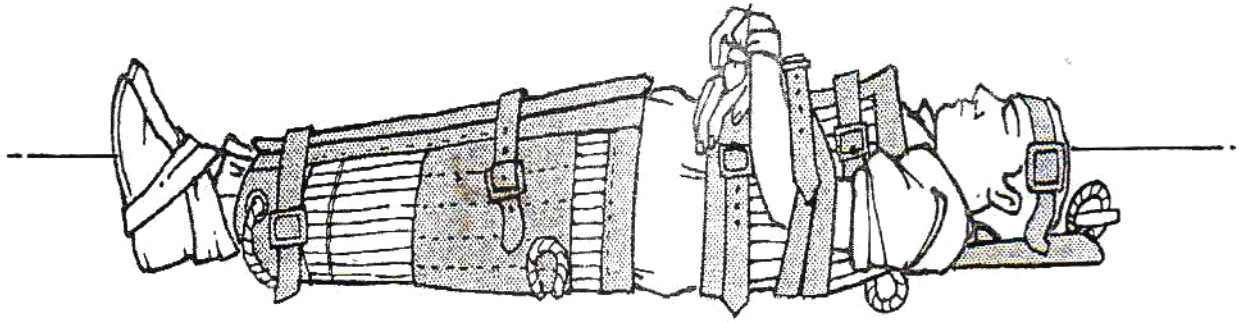

**Fig. 32 – Carriage Using a Neil Robertson Stretcher by Four Bearers**



Hoisting a casualty through a hatch

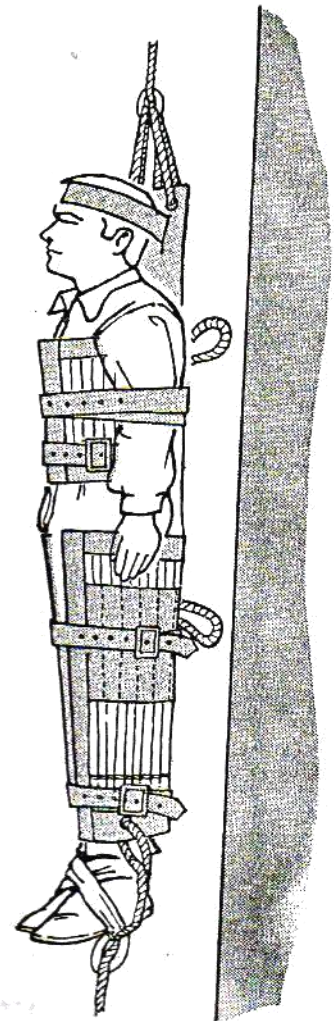

Moving a casualty vertically. Note : to steady the stretcher, a rope goes through the foot of the stretcher to a seaman below.

**Fig. 33 – Alternate use of Neil Robertson Stretcher**

7. Carriage by Transport
  - (a) By ambulance
  - (b) By ambulance train
  - (c) By helicopter
  - (d) By aircraft
  - (e) By hospital ship

## Summary

### Transportation

#### **1. Carriage by One Bearer.**

- (a) Cradle
- (b) Neck drag
- (c) Human Crutch
- (d) Pick a back
- (e) Fireman's lift

#### **2. Carriage by Two Bearers**

- (a) Two handed seat  
Three handed seat  
Four handed seat
- (b) Fore and aft method.
- (c) Kitchen chair carry.

#### **2. Carriage by Stretchers.**

## CHAPTER – 11

### OTHER TOPICS

#### Fracture

1. When a bone is broken or cracked it is called fracture.
2. **Causes.**
  - (a) **Direct Force.** When the bone breaks at the spot where force is applied. e.g., from a severe blow, bullet, by fall or crush by wheel.
  - (b) **Indirect Force.** When a bone breaks at some distance from spot where the force is applied e.g. Fracture of clavicle due to fall on out stretched hands.
    - (i) Due to forcible ligament contraction – Fracture of lower leg bone at the ankle after stumbling.
    - (ii) Due to forcible muscular contraction - Fracture patella due to sudden contraction of muscular attached to it.
    - (iii) Due to disease of bone which make them weak and easily breakable e.g. Osteomalacia, tuberculosis of bone.
3. **Types of Fracture.**
  - (a) Simple or Closed Fracture. The bone is broken but the skin surface around the damaged bone is intact.
  - (b) Compound or Open Fracture. When there is wound leading to the broken bone or the broken ends of the bone protrudes through the skin. They cause – extensive blood loss, infection.
  - (c) Complicated Closed or Open Fracture are said to be complicated when there is associated injuries to the blood vessels, nerve, muscles etc.
4. **Signs and Symptoms.**
  - (a) Pain
  - (b) Difficulty in movement
  - (c) Swelling
  - (d) Discolouration
  - (e) Deformity
  - (f) Shortening of bone
  - (g) Tenderness

- (h) Crepitus (coarse bony grating sound may be heard)
- (i) Loss of function.

5. **General Management.**

- (a) Pain is due to rubbing of broken ends of bone. Prevent rubbing by immobilisation and handle broken pieces as one.
- (b) Reassure the patient
- (c) Ensure clean airway, treat difficulty in breathing
- (d) Stop haemorrhage
- (e) Treat shock
- (f) Relieve pain
- (g) Immobilise fracture by splints & slings
- (h) Prevent infection by covering with a clean dressing.
- (i) Do not tie knot of bandage over the area of fracture
- (j) Do not move injured part unnecessarily.

6. **Types of Bandages.**

- (a) Roller
- (b) Triangular
- (c) Suspensory
- (d) T Bandage
- (e) Crepe

7. **Use of Bandages.**

- (a) Holds dressing in position.
- (b) Holds the splint in position.
- (c) Support limbs or joints.
- (d) Restrict movements.
- (e) As a sling.
- (f) Assist in lifting casualty.

8. **Splints.** These are made up of wood, metal, plastic or Cramer wire. When these are properly applied to a limb, they relieve pain by immobilizing the fractured and prevent further damage. The splint should be long enough to extend beyond the joint at the end of the fractured wound.

9. **Types.**

- (a) Body splinting
- (b) Prepared splints
- (c) Thomas splint
- (d) Improvised / other splints.

10. **Points to be Remembered While Applying Splints.**

- (a) Avoid movements
- (b) Movements should be gentle.
- (c) Maintain circulation.
- (d) Keep comfort of casualty in mind.
- (e) Splint should be firm.
- (f) Wound should be easily approachable.

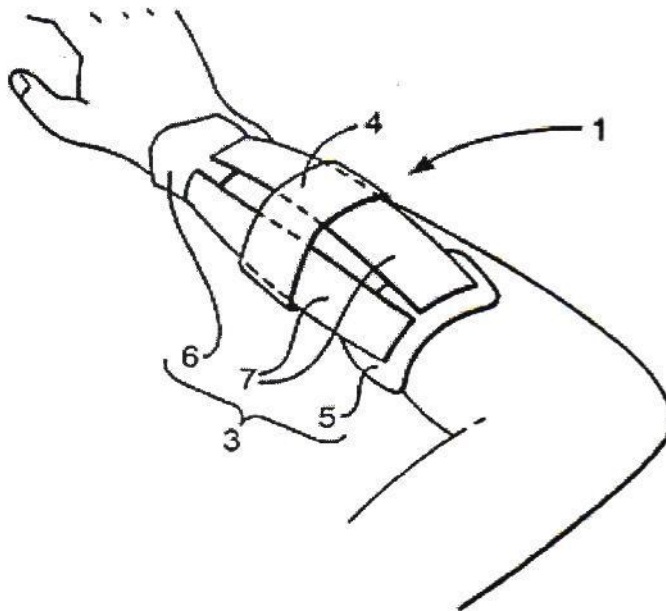

**Fig. 34 – Simple Fracture**



**Fig 35 - Bandage for Fracture of the Mandible**



**Fig 36 - Applying Triangular Bandage to Support Arm on the Chest**

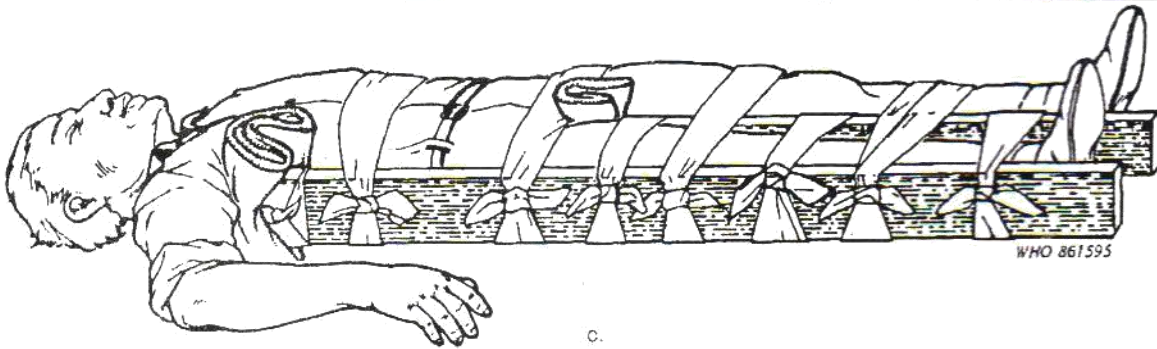

**Fig. 37 – Casualty with Fracture Pelvis**

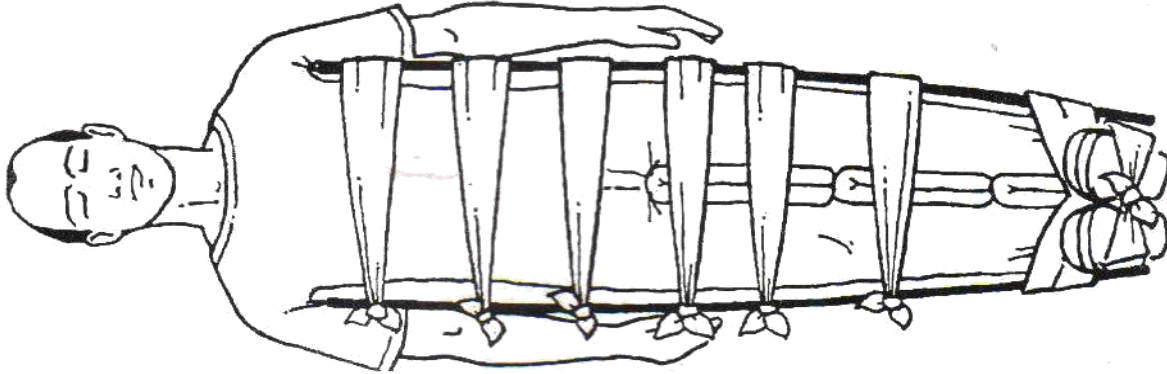

**Fig 38 - Casualty with Fracture Femur**



**Fig. 39 – An Improvised Neck Collar**

### **Cardiac Arrest**

11. **Definition.** Cardiac arrest is a sudden stoppage of the heart resulting in an inadequate cerebral circulation which leads to coma within one minute but recovery would be complete if the oxygen deficiency is relieved within 3 minutes. If oxygen deficiency exceeds more than 4-6 minutes severe and permanent brain damage will occur.

12. **Causes.**

- (a) Heart attack and myocardial infarction, Angina Pectoris.
- (b) Obstruction in the cardiac (heart) circulation.
- (c) Injury to the heart
- (d) Electrolytes imbalance
- (e) Lack of oxygen to the heart
- (f) Severe drug reaction.
- (g) Electric shock.
- (h) Due to an aesthetic drugs.
- (i) Severe bleeding.

13. **Sign of Cardiac Arrest.**

- (a) Absence of pulse in the major arteries like carotid or femoral.
- (b) The patient will be unconscious.
- (c) The skin colour will turn into blue.
- (d) The respiration will stop.
- (e) Pupils are widely dilated.
- (f) If the operation is in progress there will be no bleeding or if there is bleeding it will stop.
- (g) The person will look like dead.

14. **First Aid Management.**

- (a) First confirm the diagnosis (unconscious, death like appearance, no pulse and no respiration) and send for help.
- (b) Do not waste time and start CPR (Artificial respiration with chest compression).
- (c) Follow ABC of respiration
  - (i) A for Airway clearance.
  - (ii) B for breathing that is assist in breathing by artificial means.
  - (iii) C for Circulation that is maintain circulation by chest compression.
- (d) Place the person in supine position on a hard board.
- (e) Clear the airway of any matters. e.g. vomitus secretion or any dentures.
- (f) Hyper extend the neck by tilting it backward as far as possible and start artificial respiration (Mouth to Mouth respiration) with chest compressions.
- (g) Clear the throat hold the jaw at both mandible joints and place the resuscitation tube and give a strong blow in the Mouth.
- (h) Continue chest compression and Mouth to Mouth respiration at the rate of 5:1 in case of two rescuers.
- (i) Periodically check the pulse in the neck for carotid pulse.
- (j) Check the pupil; return of pupillary reaction indicates successful efforts.
- (k) Continue basic life support and transport the patient to hospital.

## **Drowning**

15. Drowning causes asphyxia by water, entering the lungs or by causing the throat to go into spasm thus constricting the air passage.

### 16. **What Happens in Drowning.**

- (a) Drowning is a major source of accidental death and can be a result of cold, fatigue, injury, disorientation, intoxication etc.
- (b) The drowning victim struggles to inhale air as long as possible but eventually he goes beneath the water where he must exhale air and inhale water.

### 17. **Effects of Drowning.**

- (a) Airway obstruction.
- (b) Asphyxia
- (c) Congestion of lungs
- (d) Injuries to head and neck.
- (e) Internal injuries
  - (i) Broken bones
  - (ii) Soft tissue injuries
  - (iii) Internal bleeding
  - (iv) Hypothermia

### 18. **Signs and Symptoms**

- (a) General symptoms and signs of asphyxia.
- (b) Froth around the casualty's mouth and nostrils.

### 19. **First Aid Treatment**

#### (a) **Rescuing the Victims :-**

- (i) Pull the patient from water using rope, branch, fishing pole, stick, towel, shirt etc. or lie down flat on your stomach and extend your hand or leg.
- (ii) Throw him an object that will float with line that is tyre, foam cushions, logs, boards or plastic toys.
- (iii) Make sure that your own position is safe.
- (iv) Use boat and life jacket if available.
- (v) Tow the victim to the shore.

- (vi) Do not swim to the person directly, hold him from back.
- (b) **Persons Rescued from Drowning.** Forced immersion is the primary hazard to life after surviving the initial impact of; hitting the water. It should be kept in mind that no ocean or lake has a temperature equal to body temperature. Thus in all latitudes anyone in open water will lose heat and heat loss will lower the body temperature. As the internal body temperature falls down or below normal and generalized hypothermia develops there is an increasing likelihood of cardiac arrest.
  - (i) The loss of body heat is one of the greatest hazards to the survival of a person in the sea.
  - (ii) Those rescued promptly from drowning usually recover spontaneously, if they have not spent too much time in cold water and their body temperature has not been abnormally lowered.
  - (iii) Treatment for the person who has almost drowned should consist of immediate mouth to mouth artificial respiration and heart compression.

20. **Things to Remember.**

- (a) In fresh water drowning water passes through the lungs into the circulation and may cause dilution of blood. This interferes with Oxygen exchange.
- (b) In salt water drowning, salt from the aspirated water causes the loss of large amounts of fluids from the circulation into the lungs, this causes water accumulation in the lungs and death.

**Asphyxia**

21. Asphyxia is a condition in which the lungs do not get sufficient supply of air for breathing. If this continues for some minutes, breathing and heart action stops and death occurs.

22. **Causes,**

(a) **Conditions Affecting the Air Passage.**

(i) **Spasm.**

- (aa) Food going down the wrong way that is into the air passage.
- (ab) Water getting into air passage as in case of drowning.
- (ac) Irritant gases getting into the air passage as in carbon monoxide poisoning.
- (ad) Asthma.

(ii) **Obstruction.**

- (aa) Mass of food, vomit or foreign body like artificial teeth in air passage.

- (ab) Tongue falling back in unconscious person.
  - (ac) Swelling of tissues of the throat as a result of scalds (boiling water) injury, infection, burns, corrosives and stings.
  - (ad) Drowning.
- (iii) **Compression**
- (aa) Tying a rope or scarf tightly around the neck causing strangulation.
  - (ab) Hanging or throttling (applying pressure with fingers on the wind pipe).
  - (ac) Smothering like overlying an infant and unconscious person lying face downwards on a pillow or plastic bags or sheets covering face completely for sometime.
  - (ad) Hanging, throttling, strangulation.
- (b) **Compression of the Chest.** It can be caused by fall of machinery, big beams or pillar or being crushed against the wall or barriers which leads to injury to the lungs and chest wall.
- (c) **Conditions Affecting Respiratory Mechanism.**
- (i) Fits, rabies, tetanus.
  - (ii) Nerve disease causing paralysis of chest wall or diaphragm.
- (d) **Conditions Affecting the Brain or Nerves Which Control Respiration.**
- (i) Electrical injuries
  - (ii) Poisoning.
  - (iii) Paralysis caused by a stroke or injury to the spinal cord.
  - (iv) Drugs (Morphia or barbiturates etc.)
- (e) **Conditions Affecting the Amount of Oxygen in the Blood.**
- (i) Air containing insufficient Oxygen Gas or smoke filled compartments.
  - (ii) Fire which result into Carbon Mono Oxide gas.

23. **Signs and Symptoms.**

- (a) Difficulty in breathing. The rate and depth of breathing increases.
- (b) Noisy breathing.
- (c) Veins of the neck becomes swollen.
- (d) Face, lips, nails, finger and toes turn blue.
- (e) Pulse gets faster and weaker.
- (f) Froth may appear at mouth and nostrils.
- (g) Confusion and disorientation
- (h) Unconsciousness
- (i) Fits or convulsions
- (j) Breathing may stop.

24. **Foreign Body Removal.** Heimlich Manoeuvre is used to remove a foreign body from the wind pipe/lungs, in case of choking. Figs 40 and 41 indicate the method to be used in a conscious and unconscious casualty respectively.

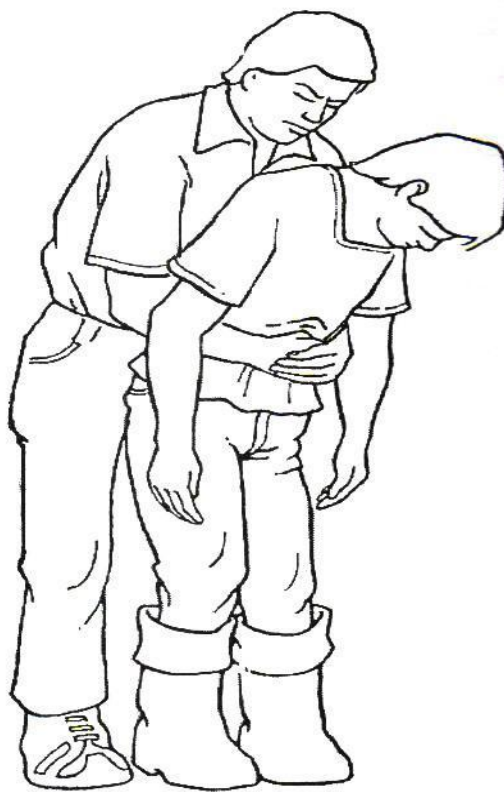

**Fig. 40 – Conscious Casualty**

Heimlich manoeuvre (rescuer standing and victim standing or sitting). Standing behind the victim, wrap your arms around his waist. Grasp your fist with your other hand and place the fist against the victim's abdomen. Press the abdomen with a quick upward thrust.

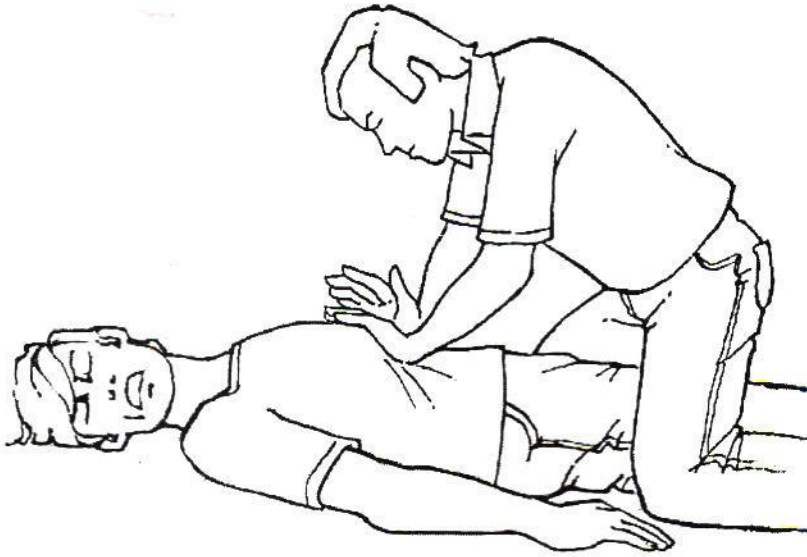

**Fig. 41 – Unconscious Casualty**

Heimlich manoeuvre (rescuer kneeling and victim lying on his back). Kneel astride the victim's hips put one hand on top of the other and place the heel of the bottom hand on the abdomen. Press in with a quick upward thrust Repeat, if necessary.

25. **First Aid Treatment.**

- (a) Remove the person from the cause or cause of asphyxia.
- (b) Clear and open the airway.
- (c) If the casualty is not breathing begin artificial respiration or mouth to mouth respiration immediately.
- (d) When breathing and pulse return, place the casualty in recovery position.
- (e) Check breathing rate, pulse and levels of consciousness at ten minute intervals.
- (f) Start Oxygen if available.
- (g) Send the casualty to hospital.
- (h) In case of cardiac arrest then continue CPR.

## Summary

### Fractures

1. Break / crack in bone.
2. Due to direct / indirect force.
- 3.

#### Types of Fractures

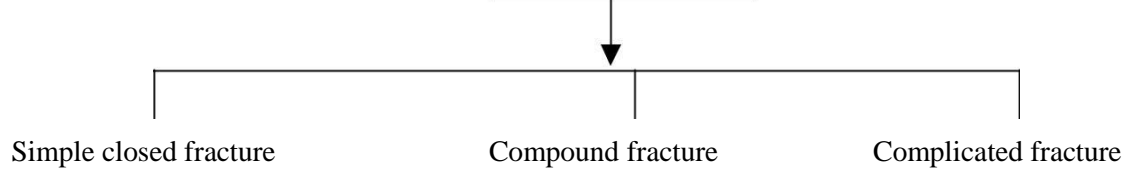

4. Symptoms of pain, swelling, difficulty in movement and deformity.
5. Management

- (a) Immobilisation with splints / slings of part and reassure patient.
- (b) Stop any bleeding.
- (c) Relieve pain

### Bandages

6.

#### Types of Bandages

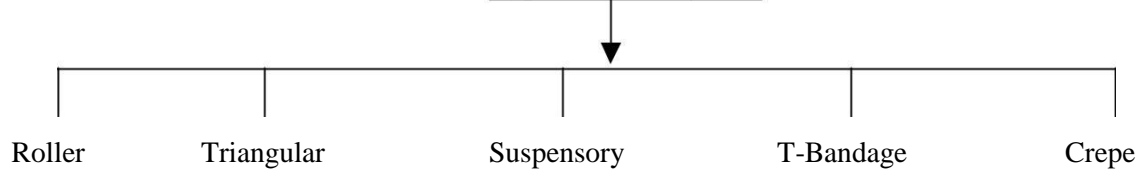

7. Uses of Bandages.
  - (a) For dressing and holding splints in place
  - (b) Supports limbs and helps immobilisation.
8. Splints.
  - (a) Made of wood, plastic or cramer wire.
  - (b) Relieve pain by immobilizing injured body part.

### **Cardiace Arrest**

9. Sudden stoppage of heart resulting in inadequate blood supply to vital organs.
10. Can be due to various causes e.g. heart attack / injury to heart, electric shock etc.
11. First aid management – Cardiopulmonary resuscitation (CPR)
  - (a) A – Airway – Maintain open airway by hyperextension of neck.
  - (b) B – Breathing - Mouth to mouth respiration.
  - (c) C – Circulation - Cardiac compression.

### **Drowning**

12.
  - (a) ABC
  - (b) Start artificial respiration in water if possible.
  - (c) If breathing, remove water first.
  - (d) Treat for shock.
  - (e) Give hot and sweet drinks if conscious.
  - (f) Treat for secondary injuries.

### **Asphyxia**

13.
  - (a) Take the person away from the cause.
  - (b) Remove the cause – water or foreign body.
  - (c) In conscious casualty use Heimlich manoeuver.
  - (d) Start oxygen when breathing starts.